

 **WARNING**

To avoid unpredictable system behavior that can cause personal injury and property damage:

- Disconnect electrical supply (when necessary) before installation, servicing, or conversion.
- Disconnect air supply and depressurize all air lines connected to this product before installation, servicing, or conversion.
- Operate within the manufacturer's specified pressure, temperature, and other conditions listed in these instructions.
- Medium must be moisture-free if ambient temperature is below freezing.
- Service according to procedures listed in these instructions.
- Installation, service, and conversion of these products must be performed by knowledgeable personnel who understand how pneumatic products are to be applied.
- After installation, servicing, or conversion, air and electrical supplies (when necessary) should be connected and the product tested for proper function and leakage. If audible leakage is present, or the product does not operate properly, do not put into use.
- Warnings and specifications on the product should not be covered by paint, etc. If masking is not possible, contact your local representative for replacement labels.

Safety Guide

For more complete information on recommended application guidelines, see the Safety Guide section of Pneumatic Division catalogs or you can download the **Pneumatic Division Safety Guide** at: www.wilkersoncorp.com

 **CAUTION**

Polycarbonate bowls and sight domes, being transparent and tough, are ideal for use with Filters and Lubricators. They are suitable for use in normal industrial environments, but should not be located in areas where they could be subjected to direct sunlight, an impact blow, nor temperatures outside of the rated range. As with most plastics, some chemicals can cause damage. Polycarbonate bowls and sight domes should not be exposed to chlorinated hydro-carbons, ketones, esters and certain alcohols. They should not be used in air systems where compressors are lubricated with fire-resistant fluids such as phosphate ester and di-ester types.

Metal bowls are recommended where ambient and/or media conditions are not compatible with polycarbonate bowls. Metal bowls resist the action of most such solvents, but should not be used where strong acids or bases are present or in salt laden atmospheres. Consult the factory for specific recommendations where these conditions exist.

TO CLEAN POLYCARBONATE BOWLS USE MILD SOAP AND WATER ONLY! DO NOT use cleansing agents such as acetone, benzene, carbon tetrachloride, gasoline, toluene, etc., which are damaging to this plastic.

Bowl guards are recommended for added protection of polycarbonate bowls where chemical attack may occasionally occur.

Installation

1. Refer to WARNING prior to installation.
2. Install as close to the point of use as possible.
3. Unit must be installed with the flow in the direction of the flow arrow on the body cover and with bowl down.
4. Avoid using reducing bushings, couplings, etc., whenever possible to install this product. These devices restrict air flow and can affect performance.
5. Do not install this product in any application where the pressure drop across the unit will exceed 8 psig (0.55 bar). This will cause the Differential Pressure Indicator to shift to RED indicating element replacement is required.
6. Maximum pressure rating is 150 psig (10.3 bar) for plastic bowl/bowl guard assembly, and 250 psig (17.2 bar) for metal bowl with sight gauge without DP indicator. Temperature range is 32°F to 125°F (0°C to 52°C) for plastic bowl/bowl guard assembly, and 32°F to 150°F (0°C to 65.5°C) for metal bowl with sight gauge without DP indicator.

7. To install a drain line, use the following procedure:
 - a. On units with the MANUAL DRAIN, attach flexible tubing having an I.D. of 3/16" (4.8 mm) to drain stem.
 - b. On units with AUTOMATIC FLOAT DRAIN, install using a 3/8 or 10mm instant tube fitting and flexible tubing.

NOTE: CONTAMINATES REMOVED FROM THE COMPRESSED AIR SYSTEM MUST BE DISPOSED OF IN ACCORDANCE WITH LOCAL, STATE AND FEDERAL STANDARDS.

Maintenance

THIS UNIT MAY BE SERVICED WITHOUT REMOVING THE UNIT FROM THE COMPRESSED AIR LINE.

1. Filter element replacement:
 - a. Differential Pressure Indicator is RED indicating that the filter element requires servicing.
 - b. Depressurize Unit and Vent System.
 - c. Remove bowl/bowl guard assembly by pushing up on bowl assembly and turning clockwise. Clean inside of bowl using a clean, dry cloth. Inspect plastic bowl for damage and replace if necessary.
 - d. Remove filter element by turning element counterclockwise, viewed from below.
 - e. Install a new filter element / o-ring seal and reassemble unit in reverse order.

NOTE: DO NOT TOUCH THE EXTERIOR FOAM COVER OF THE ELEMENT. USE THE PLASTIC BAG THE ELEMENT IS SHIPPED IN TO HOLD THE ELEMENT AND INSTALL INTO THE BODY.

2. Liquid level in the bowl must be kept below the level indicator line as marked. It is recommended practice to drain a unit equipped with the manual drain at least once during an eight (8) hour period.
3. To clean the AUTOMATIC FLOAT DRAIN, remove the drain nut and drain. **DO NOT DISASSEMBLE THIS DRAIN!** Clean the unit in warm soapy water and blow dry with a compressed air blow gun.
4. Before returning unit to service, insure that all seals have been reinstalled or replaced and bowl is locked into position with drain properly secured.
5. If the Differential Pressure Indicator no longer functions, it must be replaced.

(For Repair Kits and Replacement Parts see reverse side)

 **WARNING**

FAILURE OR IMPROPER SELECTION OR IMPROPER USE OF THE PRODUCTS AND/OR SYSTEMS DESCRIBED HEREIN OR RELATED ITEMS CAN CAUSE DEATH, PERSONAL INJURY AND PROPERTY DAMAGE.

This document and other information from The Company, its subsidiaries and authorized distributors provide product and/or system options for further investigation by users having technical expertise. It is important that you analyze all aspects of your application, including consequences of any failure and review the information concerning the product or systems in the current product catalog. Due to the variety of operating conditions and applications for these products or systems, the user, through its own analysis and testing, is solely responsible for making the final selection of the products and systems and assuring that all performance, safety and warning requirements of the application are met.

The products described herein, including without limitation, product features, specifications, designs, availability and pricing, are subject to change by The Company and its subsidiaries at any time without notice.

EXTRA COPIES OF THESE INSTRUCTIONS ARE AVAILABLE FOR INCLUSION IN EQUIPMENT / MAINTENANCE MANUALS THAT UTILIZE THESE PRODUCTS. CONTACT YOUR LOCAL REPRESENTATIVE.

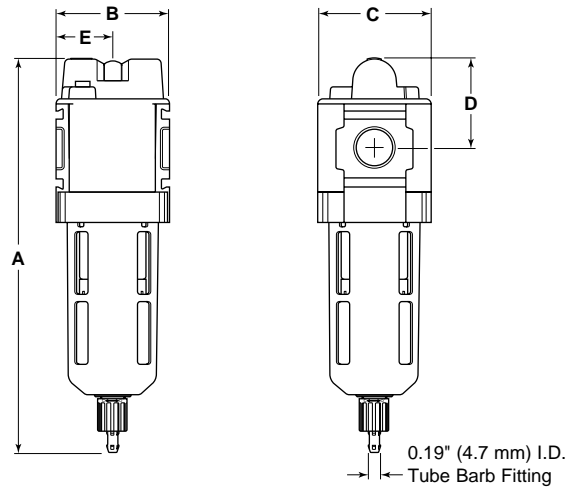
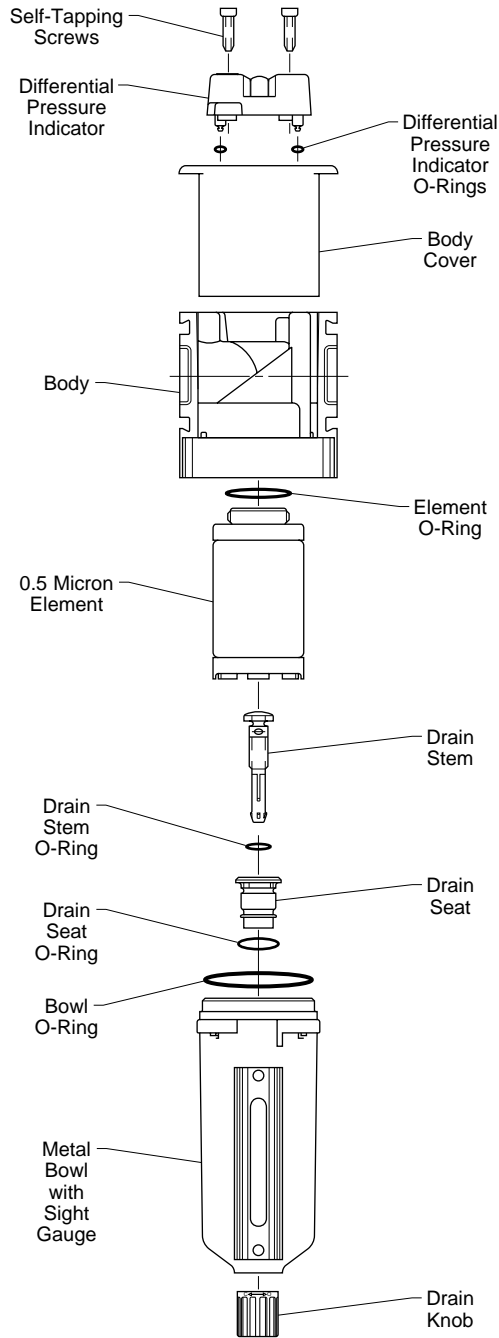

FRONT VIEW

SIDE VIEW

Dimensions

Models	A	B	C	D	E
A18	8.2 (209)	2.36 (60)	2.36 (60)	1.9 (48)	1.2 (30)
A28	9.3 (213)	2.9 (73)	2.9 (73)	1.9 (48)	1.4 (37)

Inches
(millimeters)

Repair Kits and Replacement Parts

	Element Type B 0.5 Micron	Bowl O-Ring Nitrile	Plastic Bowl/ Bowl Guard with Manual Drain	Metal Bowl/ Sight Gauge with Manual Drain
A18	MSP-96-647	GRP-96-640	GRP-96-634	GRP-96-636
A28	MSP-96-649	GRP-96-654	GRP-96-642	GRP-96-644

Drains

Manual Drain GRP-96-685

Accessories

Differential Pressure Indicator –
 Nitrile.....DP8-01-000
 Fluorocarbon.....DP8-02-000