

⚠ WARNING

To avoid unpredictable system behavior that can cause personal injury and property damage:

- Disconnect electrical supply (when necessary) before installation, servicing, or conversion.
- Disconnect air supply and depressurize all air lines connected to this product before installation, servicing, or conversion.
- Operate within the manufacturer's specified pressure, temperature, and other conditions listed in these instructions.
- Medium must be moisture-free if ambient temperature is below freezing.
- Service according to procedures listed in these instructions.
- Installation, service, and conversion of these products must be performed by knowledgeable personnel who understand how pneumatic products are to be applied.
- After installation, servicing, or conversion, air and electrical supplies (when necessary) should be connected and the product tested for proper function and leakage. If audible leakage is present, or the product does not operate properly, do not put into use.
- Warnings and specifications on the product should not be covered by paint, etc. If masking is not possible, contact your local representative for replacement labels.

⚠ CAUTION

Polycarbonate bowls, being transparent and tough, are ideal for use with Filters and Lubricators. They are suitable for use in normal industrial environments, but should not be located in areas where they could be subjected to direct sunlight, an impact blow, nor temperatures outside of the rated range. As with most plastics, some chemicals can cause damage. Polycarbonate bowls should not be exposed to chlorinated hydrocarbons, ketones, esters and certain alcohols. They should not be used in air systems where compressors are lubricated with fire-resistant fluids such as phosphate ester and diester types.

Metal bowls are recommended where ambient and/or media conditions are not compatible with polycarbonate bowls. Metal bowls resist the action of most such solvents, but should not be used where strong acids or bases are present or in salt laden atmospheres. Consult the factory for specific recommendations where these conditions exist.

TO CLEAN POLYCARBONATE BOWLS USE MILD SOAP AND WATER ONLY! DO NOT USE cleansing agents such as acetone, benzene, carbon tetrachloride, gasoline, toluene, etc., which are damaging to this plastic.

Bowl guards are recommended for added protection of polycarbonate bowls where chemical attack may occasionally occur.

Introduction

Follow these instructions when installing, operating, or servicing the product.

Application Limits

These products are intended for use in general purpose compressed air systems only.

With Polycarbonate Bowl

	kPa	PSIG	bar
Operating Pressure Maximum	1000	150	10.3
Operating Temperature Maximum:	52°C (125°F)		

With Metal Bowl

	kPa	PSIG	bar
Operating Pressure Maximum	1700	250	17.0
Operating Temperature Maximum:	80°C (175°F)		

With Automatic Drain

	kPa	PSIG	bar
Operating Pressure Maximum	68	10	0.68

Installation

1. The equipment to which the filter is attached should be internally cleaned to remove all traces of accumulated oil and dirt. Also, new pipe or hose should be installed between the filter and equipment being protected.
2. Blow all upstream pipe work clear of accumulated dirt and liquids.
3. Select a filter location as close as possible to the equipment being protected and downstream of any pressure regulator.
4. A 5 micrometer pre-filter is recommended to protect the high efficiency filter and to prolong the element life.
5. Install filter so that air flows in the direction of arrow on cover.
6. Install filter vertically with the bowl drain mechanism at the bottom. Free moisture will thus drain into the sump "quiet-zone" at the bottom of the bowl (automatic drain models are recommended as standard equipment).

Operation

Manual drain filters must be drained regularly before the separated moisture and oil reaches the bottom of the filter element. Automatic drain models will collect and dump the liquids automatically.

Pressure differential gauges should be used to determine when the maximum recommended pressure differential of 10 PSI (0.7 KG/CM²) has been reached.

DO NOT EXCEED THE RATED RECOMMENDED FLOWS. THE MINIMUM FLOW IS TEN PERCENT OF THE NOMINAL RATING.

⚠ WARNING

FAILURE OR IMPROPER SELECTION OR IMPROPER USE OF THE PRODUCTS AND/OR SYSTEMS DESCRIBED HEREIN OR RELATED ITEMS CAN CAUSE DEATH, PERSONAL INJURY AND PROPERTY DAMAGE.

This document and other information from The Company, its subsidiaries and authorized distributors provide product and/or system options for further investigation by users having technical expertise. It is important that you analyze all aspects of your application, including consequences of any failure and review the information concerning the product or systems in the current product catalog. Due to the variety of operating conditions and applications for these products or systems, the user, through its own analysis and testing, is solely responsible for making the final selection of the products and systems and assuring that all performance, safety and warning requirements of the application are met.

The products described herein, including without limitation, product features, specifications, designs, availability and pricing, are subject to change by The Company and its subsidiaries at any time without notice.

EXTRA COPIES OF THESE INSTRUCTIONS ARE AVAILABLE FOR INCLUSION IN EQUIPMENT / MAINTENANCE MANUALS THAT UTILIZE THESE PRODUCTS. CONTACT YOUR LOCAL REPRESENTATIVE.

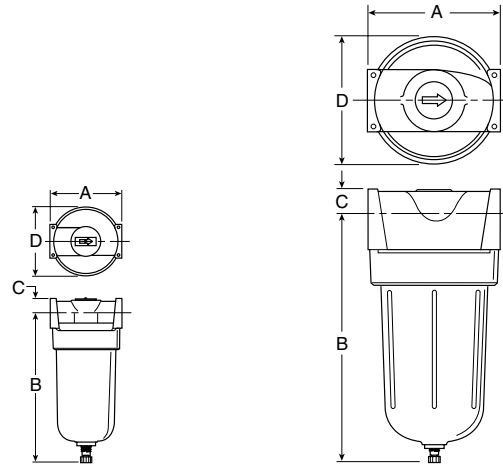
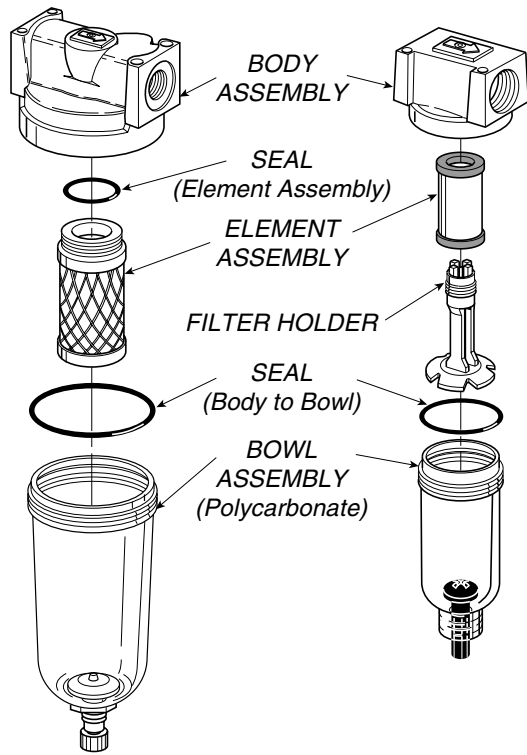

Mini, Compact & Standard

Hi-Flow

Dimensions

Model	Port Size	A	B	B (with Auto Drain)	C	D
Mini	1/4"	1.69	3.82	3.87	.39	-
		43mm	97mm	98mm	10mm	-
Compact	1/4"-3/8"	2.75	5.77	5.65	.60	2.64
		70mm	147mm	144mm	15mm	67mm
Standard	3/8", 1/2"-3/4"	3.24	7.08	6.96	.73	3.03
		82mm	180mm	177mm	19mm	77mm
Hi-Flow	3/4"-1"-1 1/4"-1 1/2"	5.00	9.38	9.26	1.18	4.84
		127mm	238mm	235mm	30mm	123mm

Maintenance

To replace the element in the filter, first shut off the air supply and relieve pressure within the filter bowl. Unscrew the bowl and unscrew the filter element. This element cannot be cleaned and should be replaced when a pressure differential of 10 PSI (0.7 KG/CM²) is reached. To install a new filter element hold the element by the bottom end cap, position the new o-ring over the top threaded cap end, turn the element gently into the body's threaded section and make sure it is screwed tightly into place.

⚠ CAUTION: Touching or handling the element section may cause contamination, spotting or migration of oil.

Automatic drains should be checked to insure they are operating correctly.

Troubleshooting

(If oil aerosol appears downstream from the filter):

1. Examine downstream air lines to determine if they were cleaned out before installation of the filter. Residual oil will contaminate an installation from new pipe work if it is not initially cleaned.
2. Determine if the sealing gasket or o-ring is in place, and that it is not cut or otherwise damaged. (When checking the element, do not touch the element's body. Always handle the element by the bottom end cap.) When reinstalling the element, turn it gently to make sure that it is screwed tightly in place.
3. Check the rate of air being used. The air flow should not exceed the rated capacity of the element, nor be less than 10% of its rated flow.
4. Check the inlet air temperature; this should not exceed 65°C (150°F). Where higher temperatures are used, oil vapor may condense if the air cools downstream of the filter.
5. Check for acid fumes or other harmful gases being drawn into the compressor intake. The element may be attacked by certain chemicals.
6. Determine the type of oil used in the compressor. Some synthetic or high flash point oils are detrimental — contact factory for advice.

Kits Available

Description	Kit No.
Element Assemblies: (Includes Seal)	
6 SCFM (Mini)	PS446
12 SCFM (Compact)	PS146
20 SCFM (Standard)	PS245
30 SCFM (Standard)	PS246
50 SCFM (Hi-Flow)	PS351B
100 SCFM (Hi-Flow)	PS350
Polycarbonate Bowl Kit	
(1) Polycarbonate Bowl with Manual Drain	
(1) Seal (Body to Bowl)	
Mini	PS404
Compact	PS166
Standard	PS266
Hi-Flow (Metal Bowl)	PS369

Accessories

Description	Kit No.			
	Mini	Compact	Standard	Hi-Flow
Automatic Drain (Includes Seal)		PS506	PS506	PS506
Bowl Guard Kit		PS107	PS207	N/A
Mounting Bracket Kit*		PS109	PS209	PS309
Metal Bowl w/Sight Glass (Manual Drain)		PS169	PS269	PS369
Polycarbonate Bowl (Automatic Drain)	PS408	PS143	PS243	N/A
Metal Bowl w/Sight Glass (Automatic Drain)		PS144	PS244	PS344C
Metal Bowl (Manual Drain)	PS447B			
Metal Bowl (Automatic Drain)	PS451			

* Not supplied with units, must be ordered separately.