

WILKERSON®

Richland, Michigan 49083

FRL-SIF-619

Precision Regulators

ISSUED: April, 2009

Supersedes: None

WRA302 Compact High Precision Regulator

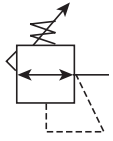

Features

- Control sensitivity of .250" (.63 cm) water column variation allows use in precision applications.
- A compensating diaphragm lets the regulator remain unaffected by supply pressure changes.
- Flow of up to 40 SCFM with 100 PSIG supply allows use in applications with high flow requirements.
- An aspirator tube compensates downstream pressure drop under flow conditions.
- A separate Control Chamber isolates the diaphragm from the main flow to eliminate hunting and buzzing.
- Unit construction lets you service the Regulator without removing it from the line.

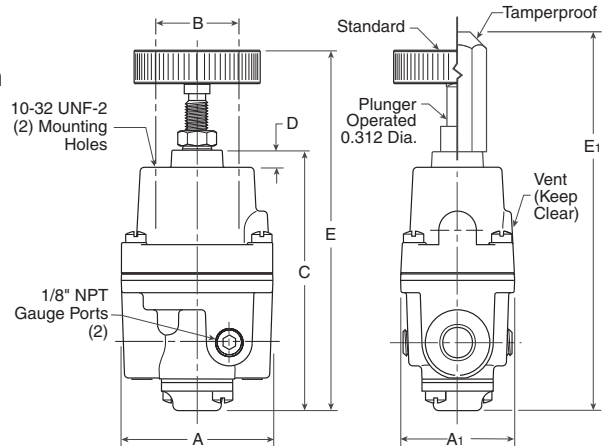

WRA302 Regulator Dimensions		
A	A1	B
2.25 (57.3)	1.70 (43.1)	1.25 (31.8)
C	D	E
3.81 (96.7)	0.25 (6.4)	5.22 (132.6)
E1		
5.56 (141.1)		

Inches (mm)

The WRA302 Regulator is designed for applications that require high capacity and accurate process control in a small package. A poppet valve which is balanced by utilizing a convoluted diaphragm, insures a constant output pressure even during wide supply pressure variations. Stability of regulated pressure is maintained under varying flow conditions through the use of an aspirator tube which adjusts the air supply in accordance with the flow velocity.

⚠ WARNING

**Product rupture can cause serious injury.
Do not connect regulator to bottled gas.
Do not exceed maximum primary pressure rating.**

Ordering Information

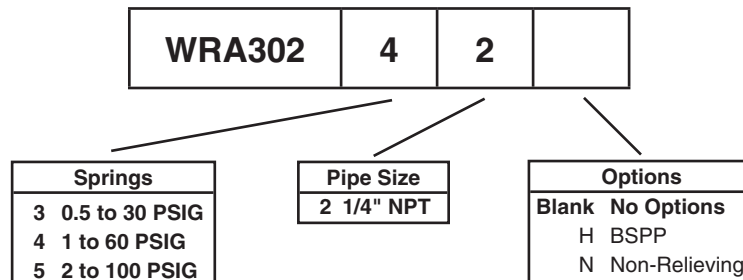

Note: Other Spring Ranges, Port Sizes, and Options Available.
Please Consult Factory

BOLD ITEMS ARE MOST POPULAR.

Technical Information

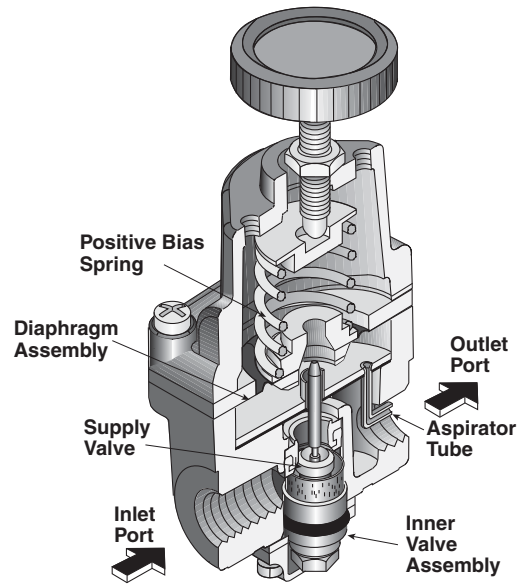
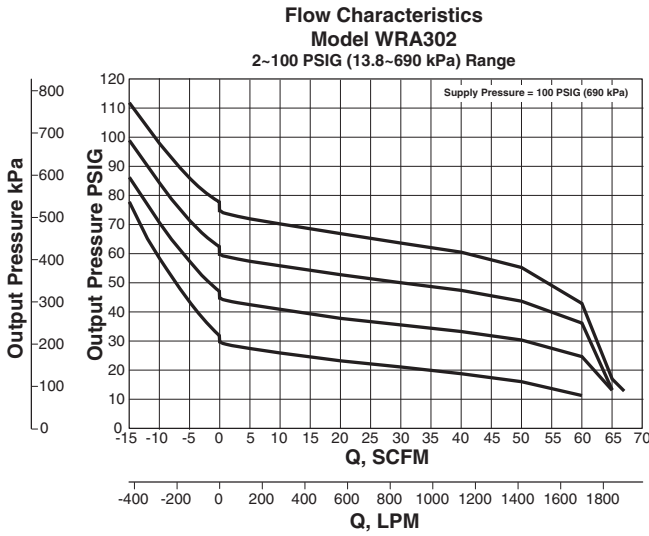

Operating Principles

The WRA302 Regulator uses the force balance principal to control the movement of the valve assembly which in turn controls the output pressure. When the regulator is adjusted for a specific set point, the downward force of the Positive Bias Spring causes the Diaphragm Assembly to move downward. The Supply Valve opens and allows air to pass to the Outlet Port. As the set point is reached, the downward force exerted by the Positive Bias spring is balanced by the upward force of the downstream pressure acting on the bottom of the Diaphragm Assembly. The resultant force moves the supply Valve upward to reduce the flow of air to the Outlet Port.

Outlet pressure is maintained as a result of balance between forces acting on the top and bottom of the Diaphragm Assembly.

WRA302 Kits and Accessories

Service Kits

- 1/2 to 30, 1 to 60, & 2 to 100 PSIG,
Nitrile, Standard..... PS16116-13
- 1/2 to 30, 1 to 60, & 2 to 100 PSIG,
Nitrile, Non-relieving PS16116-14

Tamper Resistant Kit..... PS12163

Mounting Bracket Kit PS417B

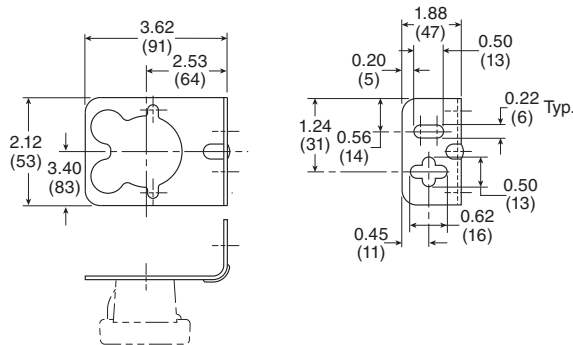

Specifications

Supply Pressure..... 250 PSIG, (17.0 bar), (1700 kPa) Maximum

Flow Capacity –
40 SCFM (68 m³/HR) @ 100 PSIG, (7.0 bar), (700 kPa) Supply and 20 PSIG, (1.5 bar), (150 kPa) Setpoint

Exhaust Capacity –
2.0 SCFM (3.4 m³/HR) where Downstream Pressure is 5 PSIG, (.35 bar), (35 kPa) above 20 PSIG, (1.5 bar), (150 kPa) Setpoint

Supply Pressure Effect –
Less than 0.2 PSIG, (.014 bar), (.14 kPa) for 100 PSIG, (7.0 bar), (700 kPa) change in Supply Pressure

Sensitivity..... .250" (.010 PSIG) (.64 cm) Water Column

Ambient Temperature-40°F to +200°F, (-40°C to 93°C)

Hazardous Locations –
Acceptable for use in Zones 1 and 2 for Gas Atmosphere:
Groups IIA and IIB and Zones 21 and 22 for Dust Atmospheres

Materials of Construction

- Body and Housing** Aluminum
- Diaphragms**..... Nitrile on Dacron
- Trim**..... Brass