

WBA208 Precision Pneumatic Input Signal Amplifier

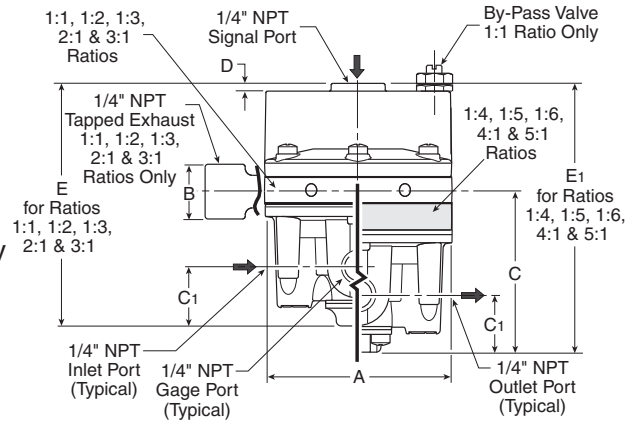

Features

- The WBA208 uses a pneumatic input signal to accurately control output pressure based on a predetermined ratio.
- A balanced Supply Valve minimizes the effects of supply pressure variation.
- An Aspirator Tube compensates downstream pressure drop under flowing conditions.
- Optional Adjustable By-Pass Needle Valve allows tuning for optimum dynamic response (1:1 ratio only).
- Optional Fixed Negative Bias allows operation with pneumatic devices that cannot be adjusted to zero input pressure.
- A separate Control Chamber isolates the diaphragm from the main flow to eliminate hunting and buzzing.
- Unit construction allows servicing without removal.
- Mounting Bracket available.



WBA208 Regulator Dimensions		
A	B	C
3.00 (76.2)	.94 (23.8)	2.13 (53.9)
C₁	D	E
.94 (23.8)	.13 (3.2)	3.88 (98.3)
E₁		
4.31 (109.5)		

Inches (mm)

Ordering Information

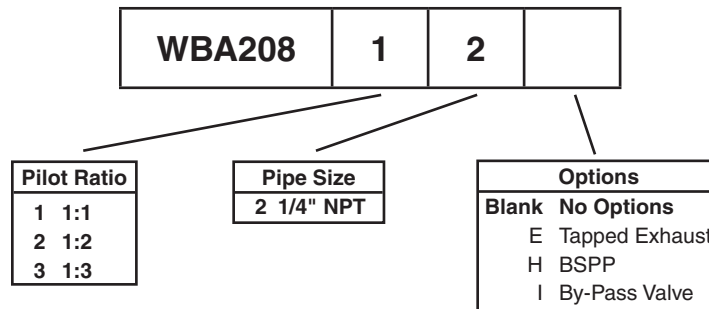

Note: Other Spring Ranges, Port Sizes, and Options Available. Please Consult Factory

BOLD ITEMS ARE MOST POPULAR.

Technical Information

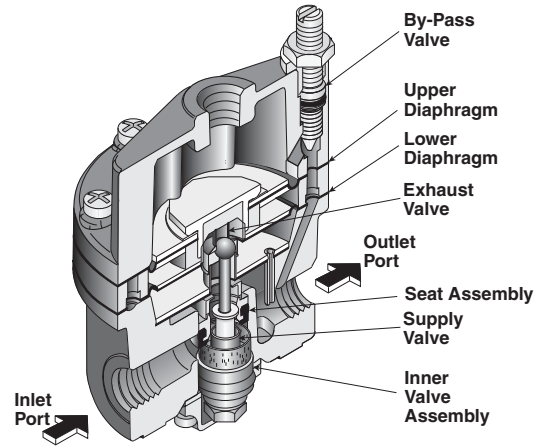
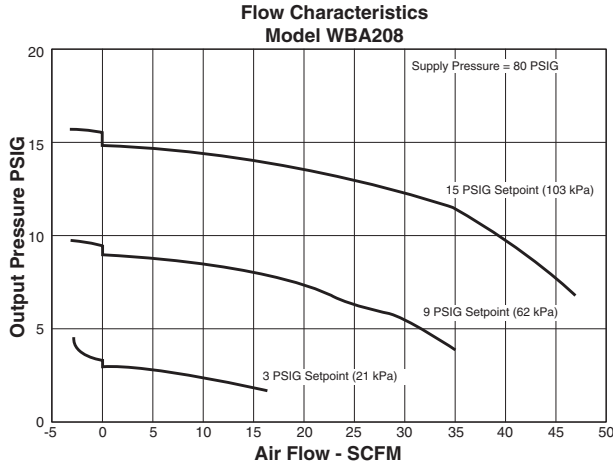

Operating Principles

The WBA208 Input Signal Amplifier is a pneumatic device capable of high flow and exhaust capacity. This device uses a force balance system to control the movement of the supply and exhaust valves.

At set point, the force due to signal pressure that acts on the top of the Upper Diaphragm balances with the force due to output pressure acting on the bottom of the Lower Diaphragm.

Materials of Construction

- Body and Housing Aluminum
- Diaphragm Nitrile on Dacron Fabric
- Trim Zinc Plated Steel, Brass

Specifications

Ratio	Signal:Output		
	1:1	1:2	1:3
Maximum Output Pressure, PSIG (bar)	150 (10.0)	150 (10.0)	150 (10.0)
Maximum Supply Pressure, PSIG (bar)	250 (17.0)	250 (17.0)	250 (17.0)
Flow Capacity SCFM, (m³/HR) 100 PSIG, (7.0 bar) Supply, 20 PSIG, (1.5 bar) Output.	45 (76.5)	45 (76.5)	45 (76.5)
Exhaust Capacity SCFM, (m³/HR) Downstream Pressure 5 PSIG, (.35 bar) Above Output Pressure Set Point of 20 PSIG, (1.5 bar).	11 (18.7)	11 (18.7)	11 (18.7)
Sensitivity (Water Column)	.250" (.64 cm)	.500" (1.27 cm)	.750" (1.9 cm)
Ratio Accuracy % of 100 PSIG, (7.0 bar) Output Span	1.0	1.0	1.0
% of Output Span with (7.0 bar) Input Span	—	—	—
Supply Pressure Effect, PSIG (bar) for change of 100 PSIG, (7.0 bar).	0.10 (.007)	0.20 (.014)	0.30 (.021)
Ambient Temperature, °F (°C)	-40 to +200 (-40 to +93)		

WBA208 Kits and Accessories

- Mounting Bracket PS09921
- Service Kits**
- 1:1 Ratio PS19513-11
- 1:1 Ratio w/ By-Pass Valve PS19513-11I
- 1:2 Ratio PS19513-12
- 1:3 Ratio PS19513-13

