

Proportional Technology

Proportional Regulator ER08

1/4" ported

Catalog 602



WILKERSON®

 **WARNING**

FAILURE OR IMPROPER SELECTION OR IMPROPER USE OF THE PRODUCTS AND/OR SYSTEMS DESCRIBED HEREIN OR RELATED ITEMS CAN CAUSE DEATH, PERSONAL INJURY AND PROPERTY DAMAGE.

This document and other information from The Company, its subsidiaries and authorized distributors provide product and/or system options for further investigation by users having technical expertise. It is important that you analyze all aspects of your application including consequences of any failure, and review the information concerning the product or system in the current product catalog. Due to the variety of operating conditions and applications for these products or systems, the user, through its own analysis and testing, is solely responsible for making the final selection of the products and systems and assuring that all performance, safety and warning requirements of the application are met.

The products described herein, including without limitation, product features, specifications, designs, availability and pricing, are subject to change by The Company and its subsidiaries at any time without notice.

Offer of Sale

The items described in this document are hereby offered for sale by The Company, its subsidiaries or its authorized distributors. This offer and its acceptance are governed by the provisions stated on the separate page of this document entitled "Offer of Sale".

© Copyright 2005, Parker Hannifin Corporation. All Rights Reserved.

WILKERSON®

Pneumatic Division
Richland, Michigan
www.wilkersoncorp.com

Proportional Regulator Applications	2-3
Why Proportional Technology ?	4
Ordering Information	5
Technical Information	6-7
Advanced Functionality	8
How to Change Parameters	9-14
Dimensional Drawings	15
Glossary	16
Offer of Sale	17

Man-Machine Interface

High Visibility LED Display
Easy to Read Characters
All Controls on the Same Face

Total Flexibility

User Friendly and Easily
Accessible Software
One Basic Unit Suits All Customer
Requirements

Special Applications

Food Version
Clean Line Design
Suitable for Washdown: IP65

Compact and Light Weight

Small Envelope
Light Weight (ER08 = 10 oz.)

Flexible Mounting Options

Stand-alone
Foot Bracket Mounting
DIN-Rail Mounting

Energy Saving

Low Watt Power Consumption
No Unnecessary Loss of Air in
Steady State



Outstanding Performance

Very Fast Response Times
Full Flow Exhaust
Excellent Linearity

Generic Industries



The new ER08 Regulator is designed to quickly and accurately adjust and maintain a set output pressure.

The unit will operate regardless of flow, in response to an electronic control signal. The media can be compressed air or an inert gas.

Applications for this technology are virtually unlimited; from paint spray control, paper manufacturing and printing to weaving and laser cutting control; in fact anywhere that requires accurate remote pressure control.

Automation

In the field of general automation, the need to control processes or movement via electronic signals is of paramount importance. The ER08 unit provides the facility to incorporate pressure control into a fully integrated control system.



Packaging and Food



The Packaging and Food industry provides another ideal area for application of the Electronic Proportional Regulator, where fine control of tension on wrapping foils and paper is required. The degree of control and the ability to manually change parameters makes this unit ideally suited to the varying requirements of this industry.

Automotive

Applications for this innovative product in the Automotive industry can be seen in major manufacturers' 'body-in-white' lines.

The control of clamping and welding forces during panel assembly is an ideal application, also accurate control in paint dipping and spraying can be achieved.

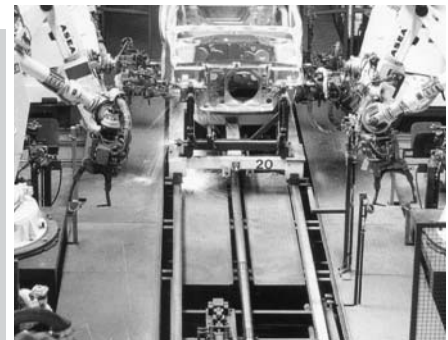

Why Proportional Technology ?

The Difference Between Open or Closed Circuit Control

Standard pressure regulators go a long way towards meeting customers needs. In most cases these regulators work well in general pneumatic and automation applications. However, sometimes the application calls for more precise pressure control. The effects of time, cycling, input, back pressure or pressure and flow variation can all cause inconsistencies in pneumatic systems. Proportional Regulators are designed to eliminate those inconsistencies.

Open Control Circuit

In a normal pressure regulated control system, the inlet pressure (p_1) is converted into the output pressure (p_2) by the regulator. The set pressure (set value) is usually manually set by adjusting the control knob and in normal circumstances the regulator maintains the output pressure (actual value).

No facility for monitoring the output pressure is provided and there is consequently no way of checking that the set value and the actual value are the same. Also, no account is taken of external influences such as air consumption by the system, which can drastically alter the actual value.

Closed Loop Control Circuit

The input signal (Electronic Control Signal) is converted into the output value (P2 Output Pressure). This output value is continuously measured and compared with the input signal. If they are different, the unit adjusts the output value to correspond to the set value, to close the loop.

Proportional Pressure Regulators

The ER08 provides all the advantages of a closed circuit regulated system. When a set value is defined via the input signal (e.g. 0-10 V), the pressure regulator sets the corresponding output pressure (e.g. 0-150 PSI/0-10 bar). At the same time the integrated pressure sensor measures the actual pressure at the unit's outlet (actual value). If the electronic regulation system finds that the actual value has deviated from the set value, it immediately corrects the actual value. This is a continuous process ensuring fast, accurate pressure regulation.

Typical Application in Automotive Body in White Welding Pressure Control

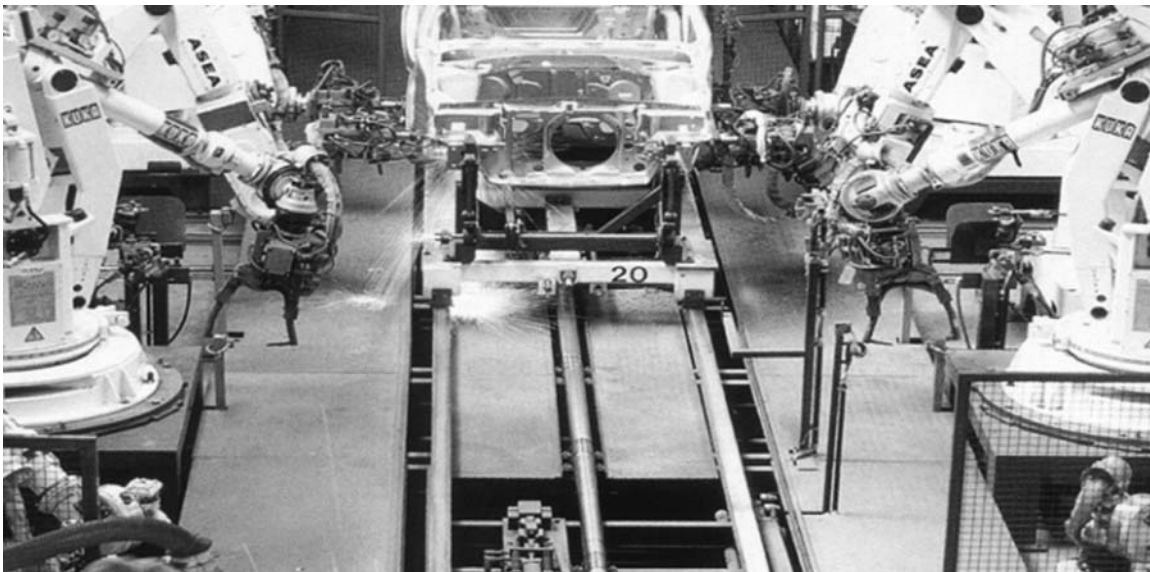

Ordering Information

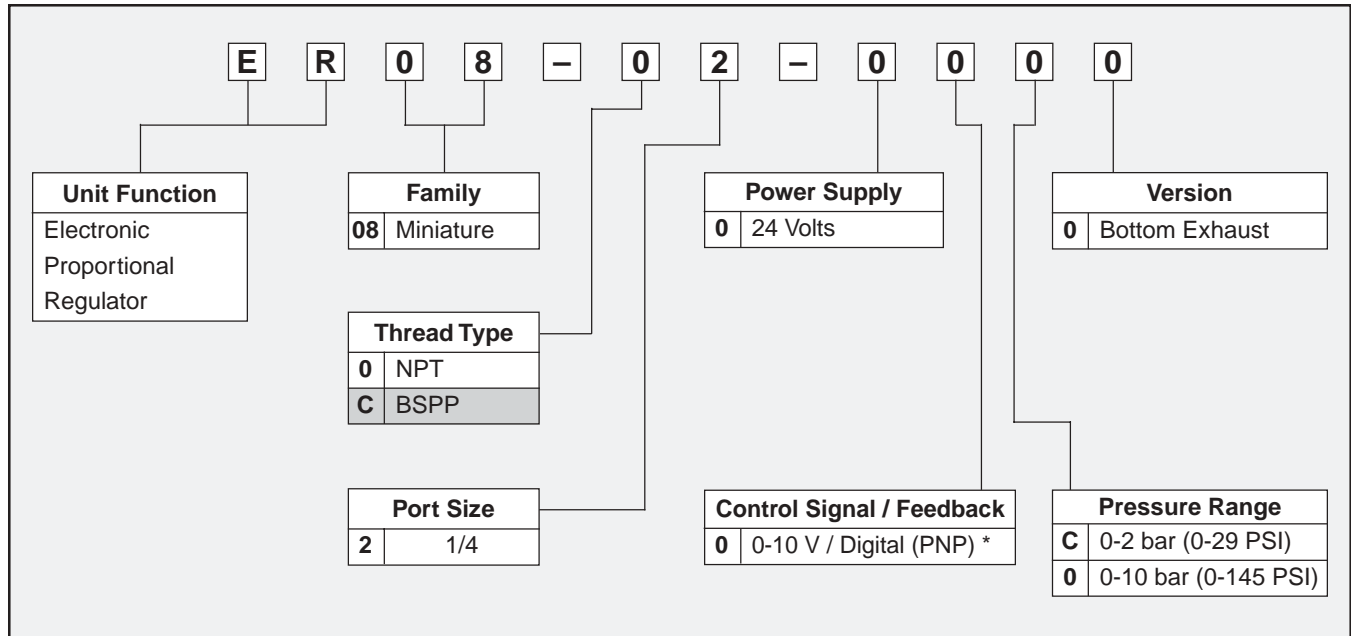

On request * Factory setting is 0-10 V control signal. 4-20 mA control signal available via parameter 4 on keypad.

Popular Options

Port Size	Order Code	Control Signal	Output Pressure
1/4	ER08-02-00C0	0-10 V	0-2 bar (29 PSI)
1/4	ER08-02-0000	0-10 V	0-10 bar (145 PSI)

Mounting Options

Order Code	Description
P3HKA00MK	DIN Rail Mounting Kit
P3HKA00MF	Foot Bracket Mounting Kit

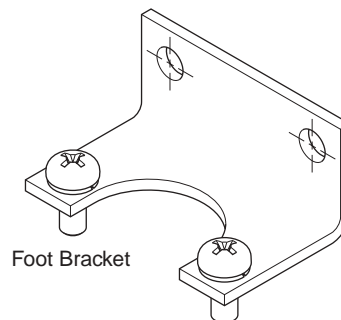
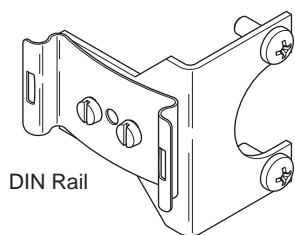

For dimensional information, refer to page 15.

Proportional Technology

Technical Information

Pneumatics

Working Media

Compressed air or inert gasses, filtered to 5 μ .

Operating Pressure

Max. Operating Pressure

2 bar unit 3 bar (43.5 PSI)

10 bar unit 10.5 bar (152 PSI)

Min. Operating Pressure P2 Pressure + 0.5 bar (7.3 PSI)

Pressure Control Range

Available in two pressure ranges, 0-2 bar (0-29 PSI) or 0-10 bar (0-145 PSI). Pressure range can be changed through the software at all times. (parameter 19)

Temperature Range

32°F to 122°F (0°C to 50°C)

Weight

ER08 10 oz.

Air Consumption

No consumption in stable regulated situation.

Display

The regulator is provided with a digital display, indicating the output pressure, either in PSI or bar.

The factory setting is as indicated on the label, can be changed through the software at all times (parameter 14).

Electronics

Supply Voltage

24 VDC +/- 10%

Power Consumption

1.1 W

Current Consumption

Max. 200 mA with no load

Control Signals

The electronic pressure regulator can be externally controlled through an analog control signal of 0-10 V, adjustable to 4-20 mA via parameter 4. See page 9.

Connections

Central M12 connector 4-pole

The electrical connections are as follows:

Pin No.	Function	Color
1 24 V	Supply	Brown
2 0 to 10 V or 4 to 20mA	Control Signal Ri = 100k Ω	White
3 0 V (GND)	Supply	Blue
4 24 V	Alarm Output Signal	Black

Schematic

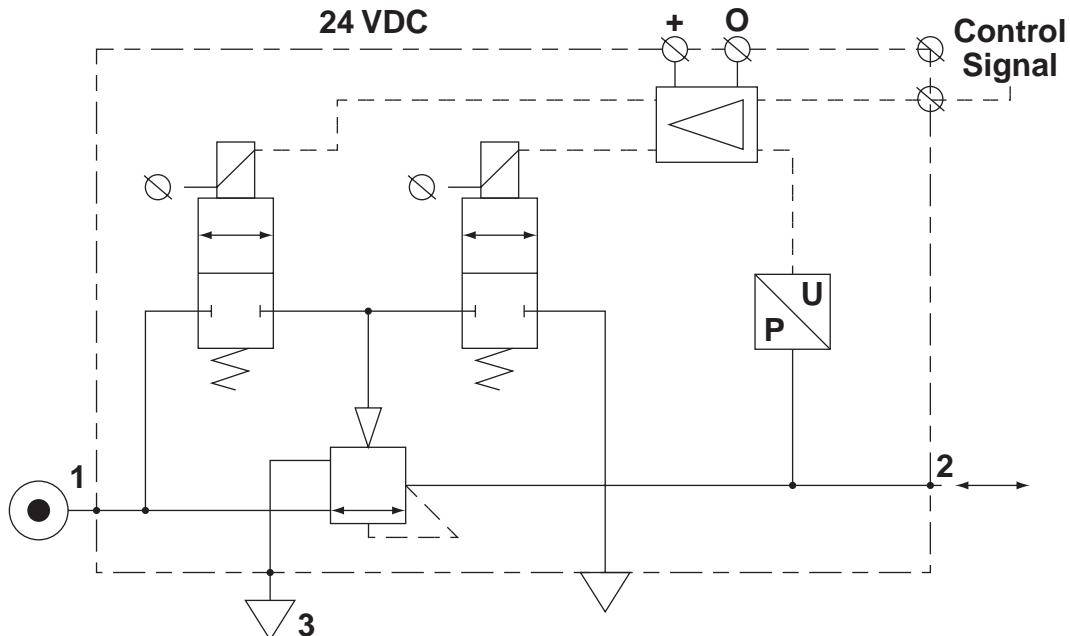

Technical Information

Dead Band

The dead band is preset at 1.3% F.S.*, adjustable via parameter 13. See page 9.

Accuracy

Linearity: = < 0.3% F.S.*

Proportional Band

The proportional band is preset at 10% F.S.*

Fail-safe Operation

After interrupting the **power supply voltage**, the present output pressure is maintained at approximately the same level. After switching the power supply on again, the pressure can be adjusted immediately by giving a new control signal.

Full Exhaust

Complete exhaust of the regulator is defined as $P_2 \leq 1\% \text{ F.S.}^*$

Degree of Protection

IP65

ER08 Kits

Seal Kit (valve seat, cover seal) 3538200
 Valve Kit (2 valves, screws, cover seal) 3538100
 Cable (M12, 4-pin connection w/2m cable) ... CB-M12-4P-2M

EU Conformity

CE: standard
 EMC: according to directive 89/336/EEC
 The new pressure regulator is in accordance with:

EN 61000-6-1:2001
EN 61000-6-2:2001
EN 61000-6-3:2001
EN 61000-6-4:2001

These standards ensure that this unit meets the highest level of EMC protection.

Mounting Position

Preferably vertical, with the cable gland on top.

Materials

Parts in contact with the working media:

- Magnet Core Steel
- Solenoid Valve Poppet FPM
- Core Housing Brass
- Solenoid Valve Housing Techno Polymer
- Regulator Housing Techno Polymer
- Valve Polyurethane
- Seats and Auxiliary Piston Delrin, Brass
- Remaining Seals NBR
- Port Connections
 - Standard Version Brass
 - Food Stainless Steel

*F.S. = Full Scale

Advanced Functionality

Pilot Valve Protection

When the required output pressure can not be achieved due to lack of input pressure, the unit will open fully and will display "NoP". Approximately every 10 seconds the unit will retry. The output pressure will then be approximately equal to the inlet pressure. As soon as the input pressure is back on the required level, the normal control function follows.

Safety Exhaust

Should the **control signal** fall below 0.1 volts, the valve will automatically dump downstream system pressure.

Fail-safe

When the **supply voltage** drops below 19 VDC, the electronic control reverts to the fail-safe mode. The last known output pressure is maintained at approximately the same level, depending upon air consumption. The digital display indicates the last known pressure setting. When the supply voltage is reinstated to the correct level, the valve moves from the fail-safe mode and the output pressure immediately follows the control signal requirement. The display indicates the actual output pressure.

Input Protection

The unit has built-in protection against failure and burnout resulting from incorrect input value, typically:

The 24 VDC supply is incorrectly connected to the setpoint input, the display will show 'OL', as an overload indication. The unit will need to be rewired and, when correctly connected, will operate normally.

The overload indicator 'OL' will also appear should the wrong input value be applied or the wrong input value be programmed: (0-10 V instead of 4-20 mA or conversely 4-20 mA rather than 0-10 V). To correct this, a different set point value should be input, or the unit reprogrammed to correct the set point value acceptance (via parameter 4).

Response Times

To fill volume of 6.1 in³ (100 cm³), connected to the outlet of the regulator:

- Pressure increase from 2 to 4 bar (30 to 60 PSI) 30 msecs
- Pressure increase from 1 to 6 bar (15 to 90 PSI) 120 msecs
- Pressure decrease from 4 to 2 bar (60 to 30 PSI) 60 msecs
- Pressure decrease from 6 to 1 bar (90 to 15 PSI) 160 msecs

Settings

The regulator is pre-set at the factory. If required, adjustments can be made.

Flow Characteristics

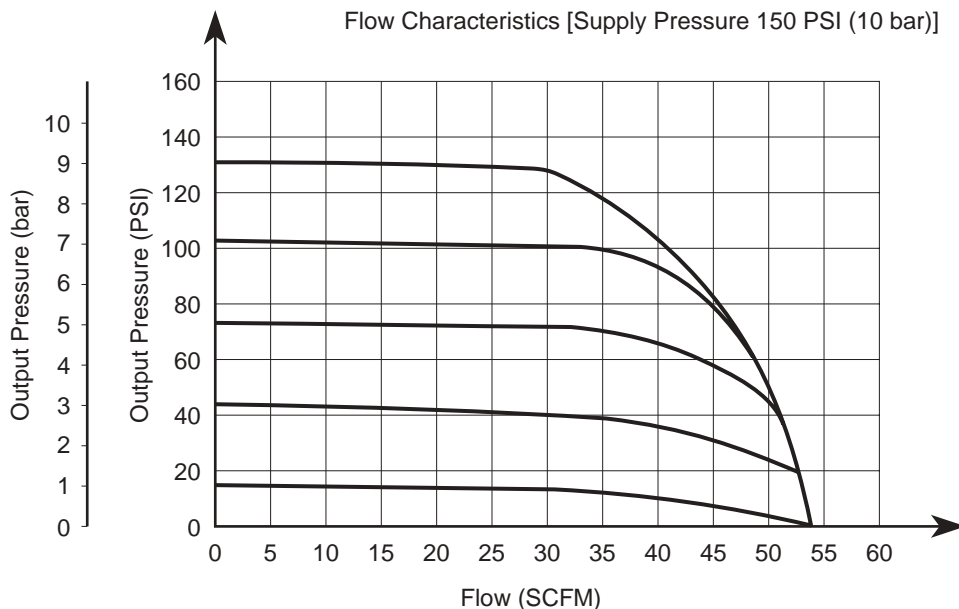

How to Change Parameters

Pressing the Accept key for 3 to 6 seconds, will activate parameter change mode. The user can then select the parameters by pressing up or down key (display will show Pxx). When parameter number is correct, pressing accept again will enter parameter number (display will show parameter value).

Pressing the up or down key will change the parameter itself (display will flash indicating parameter editing mode). Pressing the accept key will accept the new parameter value (all digits will flash while being accepted).

After releasing all keys, the next parameter number will be presented on the display (you may step to the next parameter). When no key is pressed, after 3 seconds the display will show the actual output pressure.

Only parameter numbers 0, 4, 9, 14, 18, 19, 20, 12, 13, and 21 are accessible to edit. All other parameters are fixed.

Manual Mode

When keys DOWN and UP are pressed during startup, (connecting to the 24 V power supply) manual mode is activated. This means that the user is able to in/decrease the output pressure of the ER08, by pressing the UP or DOWN key. During this action the display will blink, indicating that the manual mode is activated.











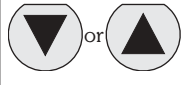

Back to Factory Setting

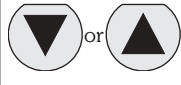
After start up. (Power is on)

Parameter 0 = 3

Entering this value in parameter 0 will store the calibrated factory data into the working parameters. (Default calibration data is used)













Parameter Number 0 – Reset Back to Factory Settings

Step	1	2	3	4	5	
Press 	 3-6 seconds					
Until Display Reads			 Flashing Decimal	 Flashing Decimal	 Flashing	
Description	Accesses changeable parameters	Accesses parameter no. 0	Displays current parameter value.	Edits parameter. 3 = standard factory settings. If other than 3, use Up or Down Arrow and accept 3	Accepts and saves new parameter setting.	Sequences to next parameter.

Set Control Signal

The unit is factory set for 0-10 V control signal. If 4-20 mA control signal is required, change parameter 4.











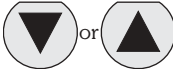

Parameter Number 4 – Set Control Signal in Volts or Milliamps

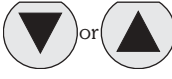
Step	1	2	3	4	5	
Press 	 3-6 seconds					
Until Display Reads			 Flashing Decimal	 Flashing Decimal	 Flashing	
Description	Accesses changeable parameters	Accesses parameter no. 4	Displays current parameter value. 1 = V 0 = mA	Edits parameter	Accepts and saves new parameter setting.	Sequences to next parameter.

Adjust Digital Display

If necessary, adjustments can be made to the digital display when using an external pressure sensor.









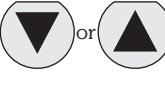

Parameter Number 9 – Adjust Digital Display Value (Pressure Calibration)

Step	1	2	3	4	5	
Press 	 3-6 seconds					
Until Display Reads			 Flashing Decimal	 Flashing Decimal	 Flashing	
Description	Accesses changeable parameters	Accesses parameter no. 9	Displays current digital display.	Use up or down arrows and accept to adjust the display value if using an external pressure sensor.	Accepts and saves new parameter setting.	Sequences to next parameter.

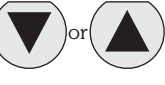
Set Pressure Scale

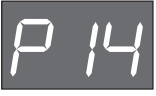
Units with NPT port threads are supplied with a factory set PSI pressure scale. Use parameter 14 to change scale to bar.



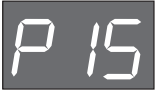







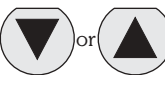

Parameter Number 14 – Set Pressure Scale in PSI or bar

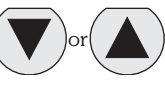
Step	1	2	3	4	5	
Press 	 3-6 seconds					
Until Display Reads			 Flashing Decimal	 Flashing Decimal	 Flashing	
Description	Accesses changeable parameters	Accesses parameter no. 14	Displays current parameter value. 1 = PSI 0 = bar	Edits parameter	Accepts and saves new parameter setting.	Sequences to next parameter.

Preset Minimum Pressure

If there is a need for a pre-set minimum pressure, use parameter 18. (Note: preset pressure is affected by % P19.)

Parameter Number 18 – Set Minimum Preset Pressure

Step	1	2	3	4	5	
Press 	 3-6 seconds					
Until Display Reads			 Flashing Decimal	 Flashing Decimal (value between 0 and 200)	 Flashing	
Description	Accesses changeable parameters	Accesses parameter no. 18	Displays current parameter value. Incremental value is: <u>2 bar unit:</u> x 2 mbar x % P19 <u>10 bar unit:</u> x 10 mbar x % P19	Edits parameter	Accepts and saves new parameter setting.	Sequences to next parameter.











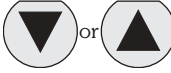

Set Pressure Correction

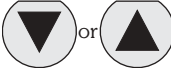
Pressure correction allows the user to set a maximum pressure as a percentage of secondary pressure F.S.
 Example: If F.S. is 10 bar, set parameter 19 to 50 for maximum preset pressure of 5 bar.

Pressure correction also affects the minimum preset pressure in parameter 18.

Example: If F.S. is 10 bar and parameter 18 is set to a value of 100 (1 bar), and parameter 19 is set to 50%, then the actual minimum preset pressure seen is 0.5 bar.











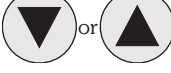

Parameter Number 19 – Set Maximum Preset Pressure

Step	1	2	3	4	5	
Press 	 3-6 seconds					
Until Display Reads			 Flashing Decimal	 Flashing Decimal (value between 0 and 100)	 Flashing	
Description	Accesses changeable parameters	Accesses parameter no. 19	Displays current parameter value. Incremental value is % of F.S.	Edits parameter	Accepts and saves new parameter setting.	Sequences to next parameter.

Behavior Control

The regulation speed of the pressure regulator can be modified by means of one parameter. (P 20)
 The value in this parameter has a range from 0-5. A higher value indicates slower regulation speed, but will be more stable.

Parameter Number 20 – Set Behavior Control

Step	1	2	3	4	5	
Press 	 3-6 seconds					
Until Display Reads			 Flashing Decimal	 Flashing Decimal (value between 0 and 5)	 Flashing	
Description	Accesses changeable parameters	Accesses parameter no. 20	Displays current parameter value.	Edits parameter 0 = custom set* 1 = fastest (narrow proportional band) 2 = fast 3 = normal 4 = slow 5 = slowest (proportional band is broad)	Accepts and saves new parameter setting.	Sequences to next parameter.











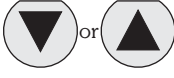

*When the value 0 is entered, you are able to create your own custom settings true parameters 12, 13 and 21.

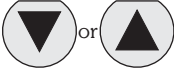
Fine Settings

Set Proportional Band

Proportional band is used for setting the reaction sensitivity of the regulator. The displayed value is X 10 mbar and has a range between 50 (0.5 bar) and 250 (2.5 bar).









Parameter Number 12 – Set Proportional Band (P20 Must be Set to 0)

Step	1	2	3	4	5	
Press 	 3-6 seconds					
Until Display Reads			 Flashing Decimal	 Flashing Decimal (value between 50 and 250)	 Flashing	
Description	Accesses changeable parameters	Accesses parameter no. 12	Displays current parameter value. Incremental value is: <u>2 bar unit:</u> x 2 mbar <u>10 bar unit:</u> x 10 mbar	Edits parameter	Accepts and saves new parameter setting.	Sequences to next parameter.

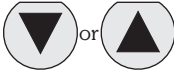
Set Deadband

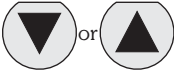
Deadband is the minimum limit of accuracy at which the regulator is set for normal operation. The displayed value is X 10 mbar and has a range between 4 (40 mbar) and 40 (400 mbar).

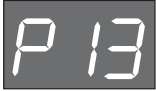
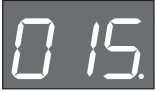

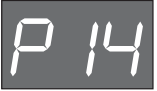









Parameter Number 13 – Set Deadband (P20 Must be Set to 0)

Step	1	2	3	4	5	
Press 	 3-6 seconds					
Until Display Reads			 Flashing Decimal	 Flashing Decimal (value between 4 and 40)	 Flashing	
Description	Accesses changeable parameters	Accesses parameter no. 13	Displays current parameter value. Incremental value is: <u>2 bar unit:</u> x 2 mbar <u>10 bar unit:</u> x 10 mbar	Edits parameter	Accepts and saves new parameter setting.	Sequences to next parameter.







Proportional Effect

Sets the speed at which the regulator adjusts either filling or exhausting. The displayed value has a range between 5 (fastest regulation) and 100 (slowest regulation).

Parameter Number 21 – Set Proportional Effect (P20 Must be Set to 0)

Step	1	2	3	4	5	
Press 	 3-6 seconds			 or 		
Until Display Reads			 Flashing Decimal	 Flashing Decimal (value between 5 and 100)	 Flashing	
Description	Accesses changeable parameters	Accesses parameter no. 21	Displays current parameter value.	Edits parameter 5 = fastest regulation 100 = slowest regulation	Accepts and saves new parameter setting.	Sequences to next parameter.

Parameter Number 39 – Displays Current Software Version

Step	1	2	3	
Press 	 3-6 seconds			
Until Display Reads			 Flashing Decimal	
Description	Accesses parameters	Accesses parameter no. 39	Displays current parameter value. XXX = current software version	

Dimensional Drawings

Bottom Exhaust Version

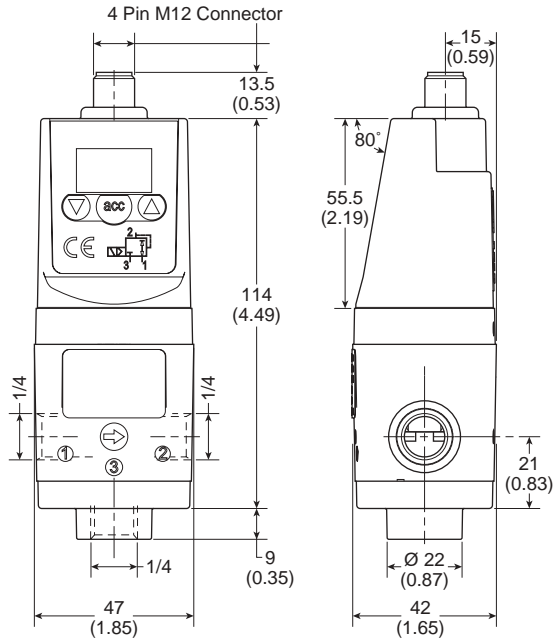

Side Exhaust Version

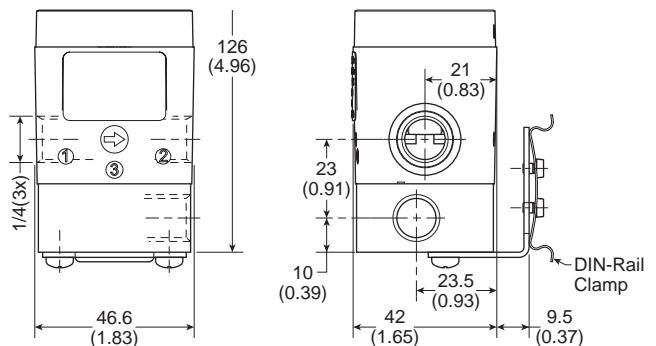
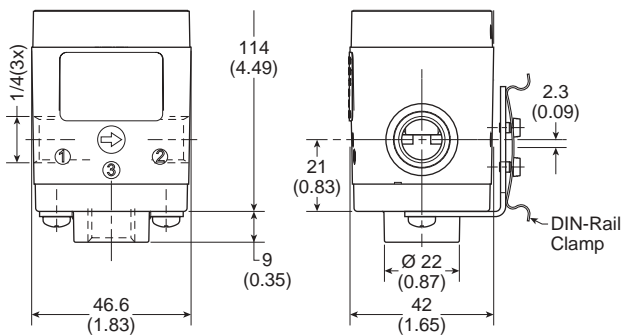
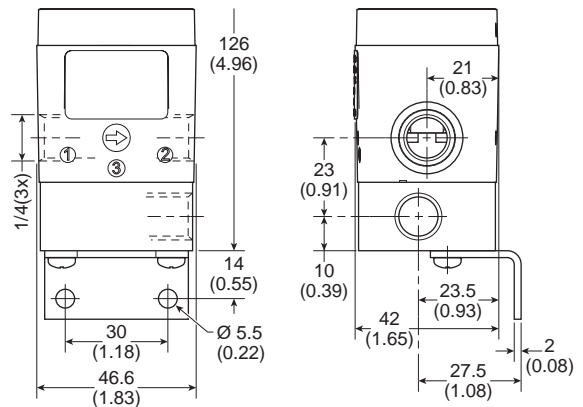
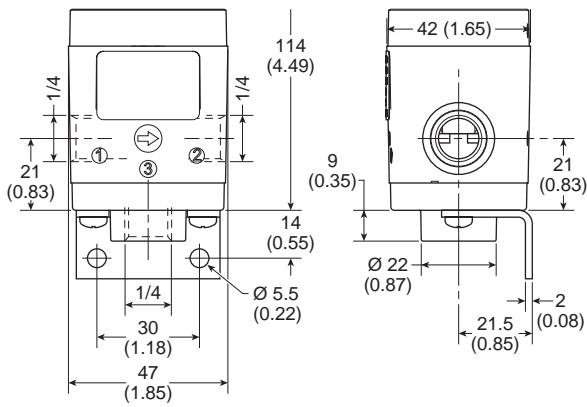
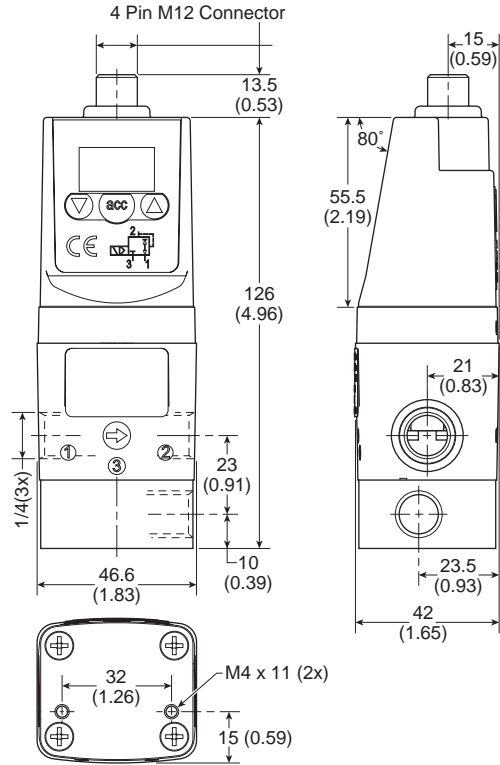

Dimensions are in mm (Inches)

Glossary

Hysteresis – The mechanical limits of accuracy of the unit. The regulator cannot be adjusted within the inherent mechanical limits of the design.

Dead Band – The minimum limit of accuracy at which the regulator is set for normal operation. This band must be equal to, or exceed, the inherent design limits of the regulator or the hysteresis band.

Proportional Band – The band used for setting reaction sensitivity of the regulator. The regulator senses the excursion from the set pressure and adjusts response in relation to the degree of excursion beyond the dead band. This band must exceed the dead band of the unit.

Proportional Effect – The speed at which the unit approaches P2 (secondary pressure).

Sensitivity – The smallest change in the control signal, or feedback signal, to cause a change in regulated output pressure.

Repeatability – a measurement of how consistently the unit can reproduce an output pressure in relation to a specific set pressure.

Linearity – A measure of how closely the relationship of output pressure vs. the control signal deviates from a straight line function.

The items described in this document and other documents or descriptions provided by The Company, its subsidiaries and its authorized distributors, are hereby offered for sale at prices to be established by The Company, its subsidiaries and its authorized distributors. This offer and its acceptance by any customer ("Buyer") shall be governed by all of the following Terms and Conditions. Buyer's order for any such item, when communicated to The Company, its subsidiaries or an authorized distributor ("Seller") verbally or in writing, shall constitute acceptance of this offer.

1. Terms and Conditions of Sale: All descriptions, quotations, proposals, offers, acknowledgments, acceptances and sales of Seller's products are subject to and shall be governed exclusively by the terms and conditions stated herein. Buyer's acceptance of any offer to sell is limited to these terms and conditions. Any terms or conditions in addition to, or inconsistent with those stated herein, proposed by Buyer in any acceptance of an offer by Seller, are hereby objected to. No such additional, different or inconsistent terms and conditions shall become part of the contract between Buyer and Seller unless expressly accepted in writing by Seller. Seller's acceptance of any offer to purchase by Buyer is expressly conditional upon Buyer's assent to all the terms and conditions stated herein, including any terms in addition to, or inconsistent with those contained in Buyer's offer. Acceptance of Seller's products shall in all events constitute such assent.

2. Payment: Payment shall be made by Buyer net 30 days from the date of delivery of the items purchased hereunder. Amounts not timely paid shall bear interest at the maximum rate permitted by law for each month or portion thereof that the Buyer is late in making payment. Any claims by Buyer for omissions or shortages in a shipment shall be waived unless Seller receives notice thereof within 30 days after Buyer's receipt of the shipment.

3. Delivery: Unless otherwise provided on the face hereof, delivery shall be made F.O.B. Seller's plant. Regardless of the method of delivery, however, risk of loss shall pass to Buyer upon Seller's delivery to a carrier. Any delivery dates shown are approximate only and Seller shall have no liability for any delays in delivery.

4. Warranty: Seller warrants that the items sold hereunder shall be free from defects in material or workmanship for a period of 18 months from date of shipment from The Company. THIS WARRANTY COMPRISES THE SOLE AND ENTIRE WARRANTY PERTAINING TO ITEMS PROVIDED HEREUNDER. SELLER MAKES NO OTHER WARRANTY, GUARANTEE, OR REPRESENTATION OF ANY KIND WHATSOEVER. ALL OTHER WARRANTIES, INCLUDING BUT NOT LIMITED TO, MERCHANTABILITY AND FITNESS FOR PURPOSE, WHETHER EXPRESS, IMPLIED, OR ARISING BY OPERATION OF LAW, TRADE USAGE, OR COURSE OF DEALING ARE HEREBY DISCLAIMED.

NOTWITHSTANDING THE FOREGOING, THERE ARE NO WARRANTIES WHATSOEVER ON ITEMS BUILT OR ACQUIRED WHOLLY OR PARTIALLY, TO BUYER'S DESIGN OR SPECIFICATIONS.

5. Limitation of Remedy: SELLER'S LIABILITY ARISING FROM OR IN ANY WAY CONNECTED WITH THE ITEMS SOLD OR THIS CONTRACT SHALL BE LIMITED EXCLUSIVELY TO REPAIR OR REPLACEMENT OF THE ITEMS SOLD OR REFUND OF THE PURCHASE PRICE PAID BY BUYER, AT SELLER'S SOLE OPTION. IN NO EVENT SHALL SELLER BE LIABLE FOR ANY INCIDENTAL, CONSEQUENTIAL OR SPECIAL DAMAGES OF ANY KIND OR NATURE WHATSOEVER, INCLUDING BUT NOT LIMITED TO LOST PROFITS ARISING FROM OR IN ANY WAY CONNECTED WITH THIS AGREEMENT OR ITEMS SOLD HEREUNDER, WHETHER ALLEGED TO ARISE FROM BREACH OF CONTRACT, EXPRESS OR IMPLIED WARRANTY, OR IN TORT, INCLUDING WITHOUT LIMITATION, NEGLIGENCE, FAILURE TO WARN OR STRICT LIABILITY.

6. Changes, Reschedules and Cancellations: Buyer may request to modify the designs or specifications for the items sold hereunder as well as the quantities and delivery dates thereof, or may request to cancel all or part of this order, however, no such requested modification or cancellation shall become part of the contract between Buyer and Seller unless accepted by Seller in a written amendment to this Agreement. Acceptance of any such requested modification or cancellation shall be at Seller's discretion, and shall be upon such terms and conditions as Seller may require.

7. Special Tooling: A tooling charge may be imposed for any special tooling, including without limitations, dies, fixtures, molds and patterns, acquired to manufacture items sold pursuant to this contract. Such special tooling shall be and remain Seller's property notwithstanding payment of any charges by Buyer. In no event will Buyer acquire any interest in apparatus belonging to Seller which is utilized in the manufacture of the items sold hereunder, even if such apparatus has been specially converted or adapted for such manufacture and notwithstanding any charges paid by Buyer. Unless otherwise agreed,

Seller shall have the right to alter, discard or otherwise dispose of any special tooling or other property in its sole discretion at any time.

8. Buyer's Property: Any designs, tools, patterns, materials, drawings, confidential information or equipment furnished by Buyer, or any other items which become Buyer's property, may be considered obsolete and may be destroyed by Seller after two (2) consecutive years have elapsed without Buyer placing an order for the items which are manufactured using such property. Seller shall not be responsible for any loss or damage to such property while it is in Seller's possession or control.

9. Taxes: Unless otherwise indicated on the face hereof, all prices and charges are exclusive of excise, sales, use, property, occupational or like taxes which may be imposed by any taxing authority upon the manufacture, sale or delivery of the items sold hereunder. If any such taxes must be paid by Seller or if Seller is liable for the collection of such tax, the amount thereof shall be in addition to the amounts for the items sold. Buyer agrees to pay all such taxes or to reimburse Seller therefore upon receipt of its invoice. If Buyer claims exemption from any sales, use or other tax imposed by any taxing authority, Buyer shall save Seller harmless from and against any such tax, together with any interest or penalties thereon which may be assessed if the items are held to be taxable.

10. Indemnity For Infringement of Intellectual Property Rights: Seller shall have no liability for infringement of any patents, trademarks, copyrights, trade dress, trade secrets or similar rights except as provided in this Part 10. Seller will defend and indemnify Buyer against allegations of infringement of U.S. patents, U.S. trademarks, copyrights, trade dress and trade secrets (hereinafter "Intellectual Property Rights"). Seller will defend at its expense and will pay the cost of any settlement or damages awarded in an action brought against Buyer based on an allegation that an item sold pursuant to this contract infringes the Intellectual Property Rights of a third party. Seller's obligation to defend and indemnify Buyer is contingent on Buyer notifying Seller within ten (10) days after Buyer becomes aware of such allegations of infringement, and Seller having sole control over the defense of any allegations or actions including all negotiations for settlement or compromise. If an item sold hereunder is subject to a claim that it infringes the Intellectual Property Rights of a third party, Seller may, at its sole expense and option, procure for Buyer the right to continue using said item, replace or modify said item so as to make it noninfringing, or offer to accept return of said item and return the purchase price less a reasonable allowance for depreciation. Notwithstanding the foregoing, Seller shall have no liability for claims of infringement based on information provided by Buyer, or directed to items delivered hereunder for which the designs are specified in whole or part by Buyer, or infringements resulting from the modification, combination or use in a system of any item sold hereunder. The foregoing provisions of this Part 10 shall constitute Seller's sole and exclusive liability and Buyer's sole and exclusive remedy for infringement of Intellectual Property Rights.

If a claim is based on information provided by Buyer or if the design for an item delivered hereunder is specified in whole or in part by Buyer, Buyer shall defend and indemnify Seller for all costs, expenses or judgements resulting from any claim that such item infringes any patent, trademark, copyright, trade dress, trade secret or any similar right.

11. Force Majeure: Seller does not assume the risk of and shall not be liable for delay or failure to perform any of Seller's obligations by reason of circumstances beyond the reasonable control of Seller (hereinafter "Events of Force Majeure"). Events of Force Majeure shall include without limitation, accidents, acts of God, strikes or labor disputes, acts, laws, rules or regulations of any government or government agency, fires, floods, delays or failures in delivery of carriers or suppliers, shortages of materials and any other cause beyond Seller's control.

12. Entire Agreement/Governing Law: The terms and conditions set forth herein, together with any amendments, modifications and any different terms or conditions expressly accepted by Seller in writing, shall constitute the entire Agreement concerning the items sold, and there are no oral or other representations or agreements which pertain thereto. This Agreement shall be governed in all respects by the law of the State of Ohio. No actions arising out of sale of the items sold hereunder or this Agreement may be brought by either party more than two (2) years after the cause of action accrues.

WILKERSON®

Wilkerson
Pneumatic Division
8676 E. M89
P.O. Box 901
Richland, MI 49083 USA

Customer/Technical Service

Tel: (269) 629-2550
Fax: (269) 629-2475
Web site: www.wilkersoncorp.com