

Moisture Indicator X08

= "Most Popular"

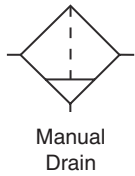

X08-02-000

Specifications

Maximum Supply Pressure	150 PSIG (10.3 bar)	
Operating Temperature	32° to 120°F (0° to 49°C)	
Port Size	NPT / BSPT-Rc	1/4
Weight	lb. (kg)	0.34 (0.15)

Materials of Construction

Body	Zinc	
Bowls	Plastic Bowl	Polyurethane
Seals	Nitrile	

Features

- Transparent Plastic Bowl Standard
- Silica Gel Changes Color For Moisture Indication

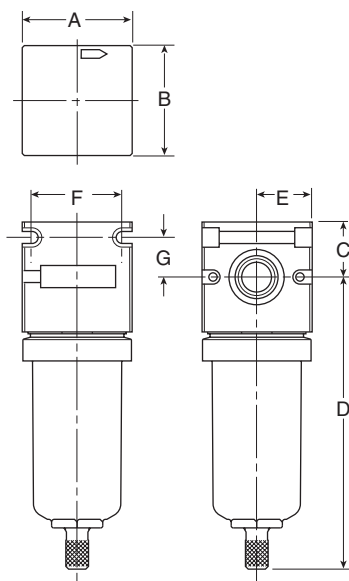

Dimensions

Models	Inches (mm)	A	B	C	D	E	F	G	H
Standard Unit X08-02-000		1.59 (40.5)	1.59 (40.5)	0.81 (20.6)	4.25 (107.9)	5.06 (128.5)	0.80 (20.2)	0.58 (14.7)	1.31 (33.3)