

WILKERSON®

First incorporated in August of 1948, Wilkerson manufactures a complete line of compressed air treatment and control products to meet a wide variety of industrial, process, consumer and health care applications. Today, Wilkerson serves over 500 different industries throughout the world.

Over the years, Wilkerson facilities, manufacturing and engineering technology have kept pace with increased sales volume, the growing need to satisfy customers' specific requirements and the demands placed on production.

Wilkerson's growing leadership in the industry is due to our determined

commitment to quality; quality of products, services and people. Our dedication to the total quality management process assures our customers that we can consistently provide the highest levels of product quality and customer service required to meet their needs.

From the very beginning, Wilkerson has sold its products through a world-wide, independent distributor network. We currently have 200 distributors throughout North America, plus an expanding network of international distributors in over 40 countries. Our distributors, who have many years of experience in compressed air treatment and

control, offer excellent product knowledge, technical assistance and local inventory. As a result of representing other complimentary products, they are able to satisfy their customers' total requirements.

Today's broad line of Wilkerson products is the result of continuing product innovations and technology advancements which frequently become industry standards. Wilkerson is dedicated to designing and manufacturing innovative products with features and operating characteristics that meet customer requirements for quality, performance, reliability, serviceability, safety and value.



WARNING

FAILURE OR IMPROPER SELECTION OR IMPROPER USE OF THE PRODUCTS AND/OR SYSTEMS DESCRIBED HEREIN OR RELATED ITEMS CAN CAUSE DEATH, PERSONAL INJURY AND PROPERTY DAMAGE.

This document and other information from The Company, its subsidiaries and authorized distributors provide product and/or system options for further investigation by users having technical expertise. It is important that you analyze all aspects of your application including consequences of any failure, and review the information concerning the product or system in the current product catalog. Due to the variety of operating conditions and applications for these products or systems, the user, through its own analysis and testing, is solely responsible for making the final selection of the products and systems and assuring that all performance, safety and warning requirements of the application are met.

The products described herein, including without limitation, product features, specifications, designs, availability and pricing, are subject to change by The Company and its subsidiaries at any time without notice.

Offer of Sale

The items described in this document are hereby offered for sale by The Company, its subsidiaries or its authorized distributors. This offer and its acceptance are governed by the provisions stated on the separate page of this document "Offer of Sale".

Mini Disposable Inline Desiccant Dryer DD10

 = "Most Popular"

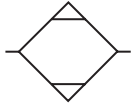

Used at the point-of-use, this disposable, mini inline desiccant dryer removes all traces of water vapor, oil vapor and dirt. It is often used directly upstream of blow guns or spray guns as final protection for critical parts blow off and paint spraying. Install in either direction; it functions in both directions.

A 40 micron, porous bronze element removes fine dirt particles, an oil removing media removes oil vapor, and desiccant beads absorb water vapor. The see-through housing shows desiccant color change from the original orange to a green color in the desiccant beads, which indicates that the dryer needs to be replaced.

Features

- Polycarbonate Material Allows Clear Desiccant Visibility
- Disposable
- Used for Parts Blow Off
- Protection for Paint Guns Below the Filter / Dryer
- Non-toxic Desiccant Standard

Non-metallic material is highly resistant to chemicals.

See through housing shows color change when dryer needs replacement.

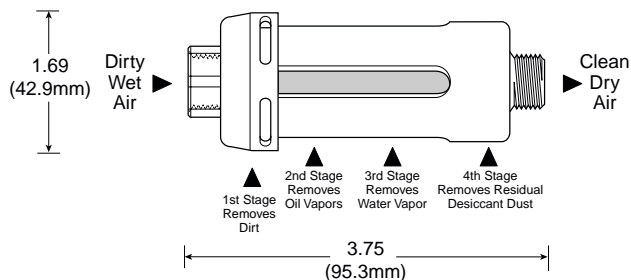

Specifications

Maximum Pressure Rating	125 PSIG (0 to 8.6 bar)	
Maximum Temperature Rating	130°F (54°C)	
Maximum Flow Capacity	15 SCFM	
Port Size	NPT	1/4
Weight	lb. (g)	2.8 oz. (79.4)

Materials of Construction

Housing	Polycarbonate
---------	---------------

Installation

The DD10 is equipped with a 1/4" NPT (F) and (M) ports and can be installed in either direction. When installing the filter / dryer hand tighten to a leak proof seal. Do not use any mechanical means to hold the filter / dryer and do not over torque the threads.

Operation

1. The unique feature of the filter / dryer design allows you to visually see when it is time to install a new DD10 by observing the color change from the original dark color to a complete light transparent color in the desiccant beads.
2. Do not attempt to clean the filter / dryer as the use of solvents, ketones, etc., will adversely affect the plastic housing.
3. Keep the hose free of snags. Extra tension on the filter / dryer assembly could break the unit at the connecting ports. To clear stuck hoses, grasp hose below the filter / dryer.

F
Dryers

Ordering Information

Model Type	Port Size	Model Number
DD10	1/4	DD10-02

Manual Desiccant Dryer Numbering System

= "Most Popular"

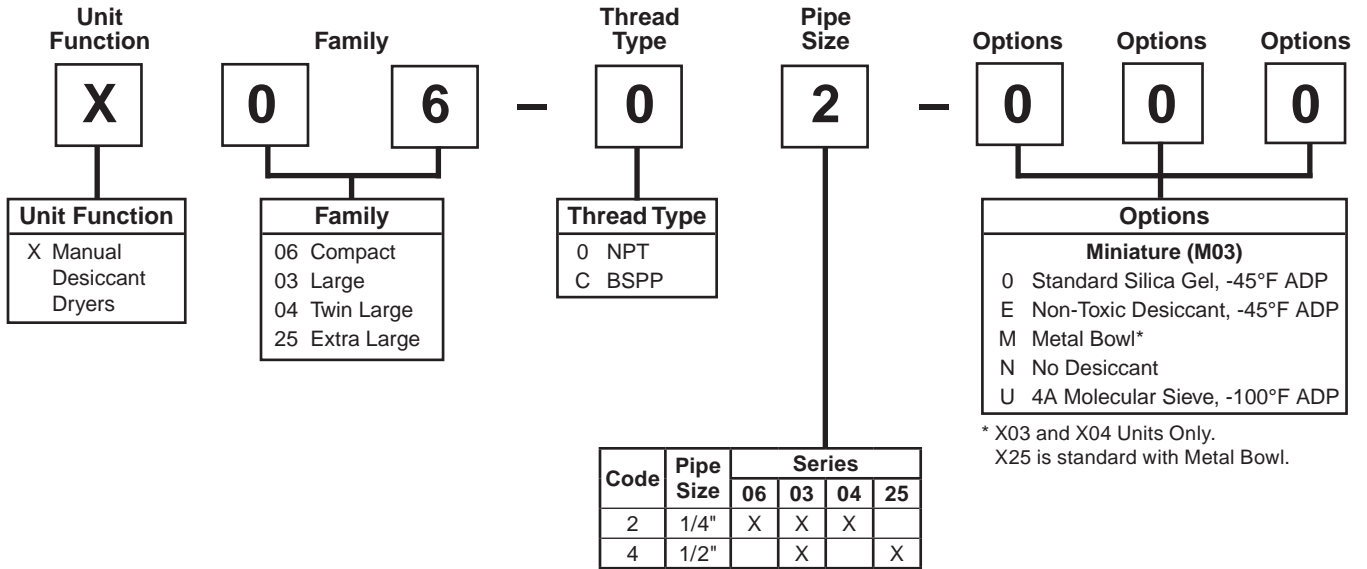

If more than one option is desired, arrange them in alphabetical order in positions 6, 7, and 8.

NOTE: 000 in position 6, 7, and 8 signifies standard product.

F
Dryers

Desiccant Dryer X06

= "Most Popular"

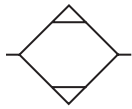

X06-02-000

Features and Benefits

- Atmospheric Dew Points as Low as -100°F
- No Electrical Connection Necessary
- Color change of the Desiccant Provides an Instant Status of the Compressed Air System

Specifications

Atmospheric Dew Point*—		
Model 000	Silica Gel	-45°F (-43°C)
Model E00	Silica Gel (Non-toxic)	-45°F (-43°C)
Model U00	4A Molecular Sieve	-100°F (-52°C)
Maximum Continuous Air Flow*		5 SCFM (2.3 dm ³ /s)
Maximum Pressure		150 PSIG (10.3 bar)
Maximum Temperature		125°F (52°C)
Port Size	NPT / BSPP-G	1/4
Total Air Flow*	1/4	600 SCF (16.6 m ³)
Total Minutes of Operation @ Continuous Air Flow		120 Minutes
Weight (with Desiccant)	lb. (kg)	1.13 (0.51)
Weight Desiccant Alone	lb. (kg)	0.25 (0.11)

* With dry desiccant at 100 PSIG (7 bar) and 70°F 21°C), saturated inlet (100% RH).

Materials of Construction

Body		Zinc
Bowls	Plastic	Polycarbonate
Bowl Guard		Aluminum
Seals		Fluorocarbon

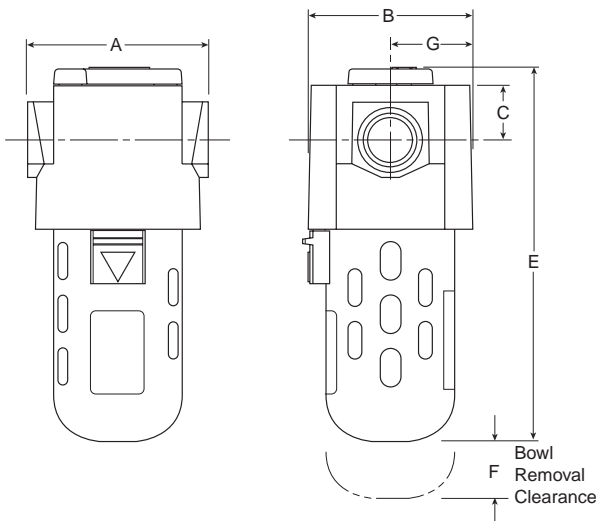

Dimensions

Models	Inches (mm)	A	B	C	E	F	G
Standard Unit X06-02-000		2.99 (75.9)	2.72 (69)	.90 (22.8)	6.41 (162.8)	1.50 (38)	1.36 (34.5)

= "Most Popular"

Replacement Parts

- Bowl Guard GRP-95-013
- Bowl O-ring GRP-95-259
- Transparent Bowl DRP-96-459

Replacement Desiccant Kits

Silica Gel (000) -40°F ADP

Old Replacement Kit Number	New Replacement Kit Number	# of Replacement Charges for X06
DRP-95-303	DRP-04-10B/001	1
	DRP-04-10B/005	5

Non Toxic Desiccant (E00) -40°F ADP

Old Replacement Kit Number	New Replacement Kit Number	# of Replacement Charges For X06
	DRP-04-447/001	1
	DRP-04-447/005	5

4A Molecular Sieve (U00) -100°F ADP

Old Replacement Kit Number	New Replacement Kit Number	# of Replacement Charges For X06
DRP-95-304	DRP-04-514/001	1
	DRP-04-514/005	5

Typical Installation Arrangement

-45°F ADP Models:

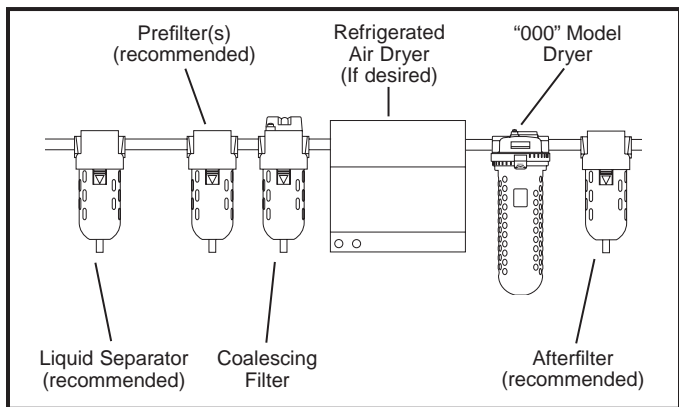

-100°F ADP Models:

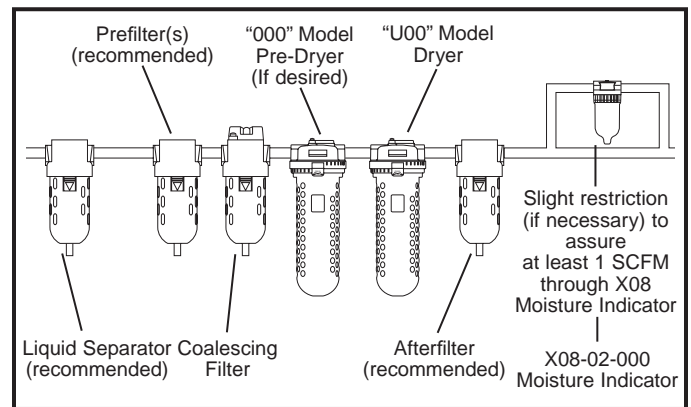

Ordering Information

Model Type	Port Size	Polycarbonate Bowl
X06	1/4	X06-02-000

Options - To order an option supplied with the unit model, add the appropriate coded suffix letter in the designated position of the model number.

Desiccant Dryer X03 / X04

= "Most Popular"

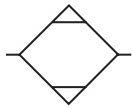

X03-02-000

Features and Benefits

- Atmospheric Dew Points as Low as -100°F
- No Electrical Connection Necessary
- Twin Units Available for Double Service Life
- Color change of the Desiccant Provides an Instant Status of the Compressed Air System

Specifications

Atmospheric Dew Point*—		
Model 000	Silica Gel	-45°F (-43°C)
Model E00	Silica Gel (Non-toxic)	-45°F (-43°C)
Model U00	4A Molecular Sieve	-100°F (-52°C)
Maximum Continuous Air Flow*		10 SCFM (4.7 dm ³ /s)
Maximum Pressure		150 PSIG (10.3 bar)
Maximum Temperature —		
X03 Transparent Bowl		125°F (52°C)
X03 Metal Bowl		150°F (66°C)
X04 Transparent Bowl		125°F (52°C)
Port Size —		
X03	NPT / BSPP-G	1/4, 1/2
X04	NPT / BSPP-G	1/4
Total Air Flow*	1/4	11,000 SCF (311 m ³)
Total Minutes of Operation @		
Continuous Air Flow	X03	440 Minutes
	X04	880 Minutes
Weight (with Desiccant) lb. (kg) —		
X03 Transparent Bowl		7.4 (3.4)
X03 Metal Bowl		6.8 (3.1)
X04 Transparent Bowl		15.0 (6.8)
Weight Desiccant Alone lb. (kg) —		
X03 Transparent Bowl		1.8 (0.8)
X03 Metal Bowl		1.3 (0.6)
X04 Transparent Bowl		3.6 (1.6)

* With dry desiccant at 100 PSIG (7 bar) and 70°F 21°C), saturated inlet (100% RH).

Materials of Construction

Body	Zinc	
Bowls	Plastic	Polycarbonate
	Metal Bowl	Aluminum
Bowl Guard	Aluminum	
Seals	Fluorocarbon	

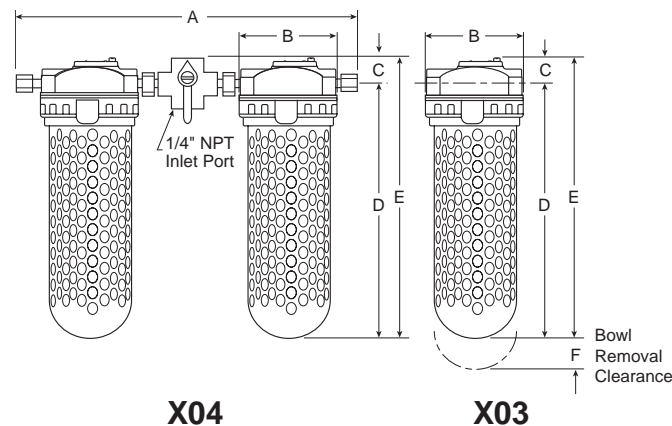

Dimensions

Models	Inches (mm)	A	B	C	D	E	F
Standard Unit X03-02-000		—	4.79 (121.6)	1.23 (31)	12.60 (320)	13.83 (351)	2.00 (50.8)
Metal Bowl X03-02-M00		—	4.79 (121.6)	1.23 (31)	12.60 (320)	13.83 (351)	2.00 (50.8)
Standard Twin Unit X04-02-000		14.42 (366)	4.79 (121.6)	1.23 (31)	11.71 (297.4)	12.65 (322)	2.00 (50.8)

= "Most Popular"

Replacement Parts

Bowl Guard –	
X03 / X04 Transparent Bowl.....	GRP-95-810
Bowl O-ring	GRP-95-256
Clamp Ring	GRP-96-404
Moisture Indicator* –	
X03 Metal Bowl.....	DRP-95-623
Replacement Cap for Moisture Removal.....	GRP-95-020
Screen Assembly	DRP-96-434
Transparent Bowl –	
X03 / X04	GRP-95-089
Tube Assembly with Screen –	
X03 / X04 Transparent Bowl.....	DRP-96-435
X03 Metal Bowl.....	DRP-96-451

* The Moisture Indicator contains a weep orifice to provide an air sample to the moisture indicating paper. Air bleed from this indicator is necessary and normal.

Replacement Desiccant Kits

Silica Gel (000) -40°F ADP

Old Replacement Kit Number	New Replacement Kit Number	# of Replacement Charges for X03
DRP-85-059	DRP-14-10B/002	1
	DRP-14-10B/008	4

Non Toxic Desiccant (E00) -40°F ADP

Old Replacement Kit Number	New Replacement Kit Number	# of Replacement Charges For X03
	DRP-14-447/002	1
	DRP-14-447/008	4

4A Molecular Sieve (U00) -100°F ADP

Old Replacement Kit Number	New Replacement Kit Number	# of Replacement Charges For X03
DRP-85-060	DRP-14-514/002	1
	DRP-14-514/008	4

Note: Since X04 consists of two X03 dryers assembled together the amount of desiccant required for a total recharge is twice the amount listed above.

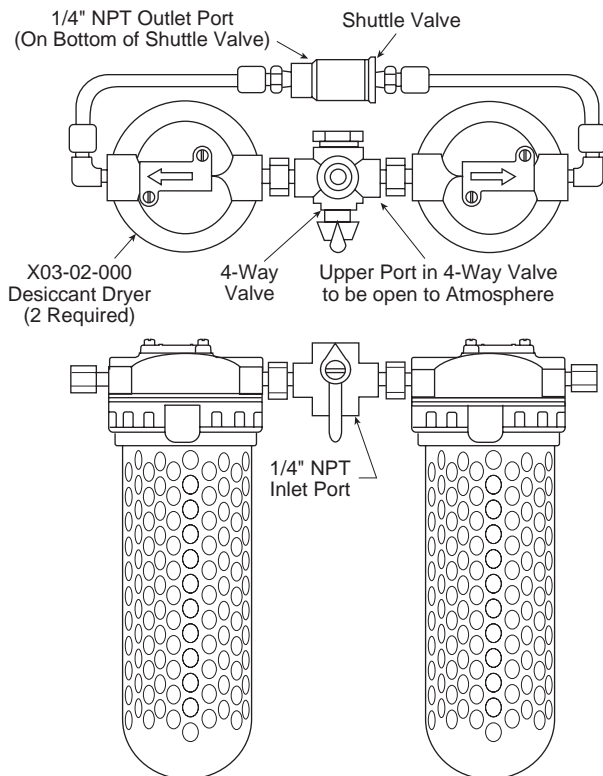

X04-02-000

Ordering Information

Model Type	Port Size	Polycarbonate Bowl	Metal Bowl
X03	1/4	X03-02-000	X03-02-M00
X04	1/4	X04-02-000	X04-02-M00

Options - To order an option supplied with the unit model, add the appropriate coded suffix letter in the designated position of the model number.

Desiccant Dryer X25

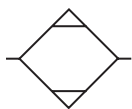

X25-04-000

Features and Benefits

- Atmospheric Dew Points as Low as -100°F
- No Electrical Connection Necessary
- Color change of the Desiccant Provides an Instant Status of the Compressed Air System

Ordering Information

Model Type	Port Size	Metal Bowl
X25	1/2	X25-04-000

Options - To order an option supplied with the unit model, add the appropriate coded suffix letter in the designated position of the model number.

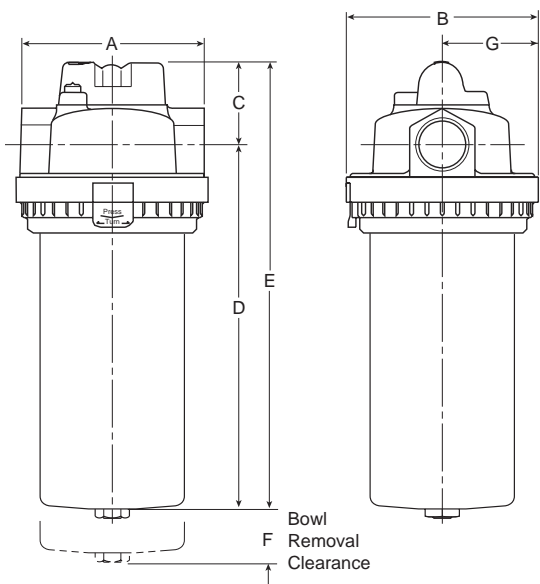

Dimensions

Models	Inches (mm)	A	B	C	D	E	F	G
Standard Unit X25-04-000		4.61 (117)	4.79 (121.6)	1.70 (43)	19.58 (497)	21.28 (540.5)	2.00 (50.8)	2.39 (60.8)

= "Most Popular"

Specifications

Atmospheric Dew Point*-		
Model 000	Silica Gel	-45°F (-43°C)
Model E00	Silica Gel (Non-toxic)	-45°F (-43°C)
Model U00	4A Molecular Sieve	-100°F (-52°C)
Maximum Continuous Air Flow*	25 SCFM (11.8 dm ³ /s)	
Maximum Pressure	150 PSIG (10.3 bar)	
Maximum Temperature	150°F (66°C)	
Port Size	NPT / BSPP-G	1/2
Total Air Flow*	11,000 SCF (311 m ³)	
Total Minutes of Operation @ Continuous Air Flow	440 min.	
Weight (with Desiccant)	lb. (kg)	11.23 (5.1)
Weight Desiccant Alone	lb. (kg)	4.4 (2.0)

* With dry desiccant at 100 PSIG (7 bar) and 70°F (21°C), saturated inlet (100% RH).

Materials of Construction

Body	Zinc	
Bowls	Metal Bowl	Aluminum
Bowl Guard	Aluminum	
Seals	Fluorocarbon	

Replacement Parts

Bowl O-ring	GRP-95-256
Clamp Ring	GRP-96-404
Moisture Indicator* DRP-95-623	
Replacement Cap for Moisture Removal.....	GRP-95-020
Screen Assembly	DRP-96-434
Tube Assembly with Screen	DRP-95-622

* The Moisture Indicator contains a weep orifice to provide an air sample to the moisture indicating paper. Air bleed from this indicator is necessary and normal.

Replacement Desiccant Kits

Silica Gel (000) -40°F ADP

Old Replacement Kit Number	New Replacement Kit Number	# of Replacement Charges for X25
DRP-85-280	DRP-14-10B/005	1
	DRP-14-10B/015	3

Non Toxic Desiccant (E00) -40°F ADP

Old Replacement Kit Number	New Replacement Kit Number	# of Replacement Charges For X25
	DRP-14-447/005	1
	DRP-14-447/015	3

4A Molecular Sieve (U00) -1000F ADP

Old Replacement Kit Number	New Replacement Kit Number	# of Replacement Charges For X25
DRP-85-281	DRP-14-514/005	1
	DRP-14-514/015	3

Moisture Indicator X08

 = "Most Popular"

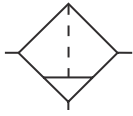

Manual
Drain



X08-02-000

Features

- Transparent Plastic Bowl Standard
- Silica Gel Changes Color For Moisture Indication

Specifications

Maximum Supply Pressure	150 PSIG (10.3 bar)	
Operating Temperature	32° to 120°F (0° to 49°C)	
Port Size	NPT / BSPT-Rc	1/4
Weight	lb. (kg)	0.34 (0.15)

Materials of Construction

Body	Zinc	
Bowls	Plastic Bowl	Polyurethane
Seals	Nitrile	

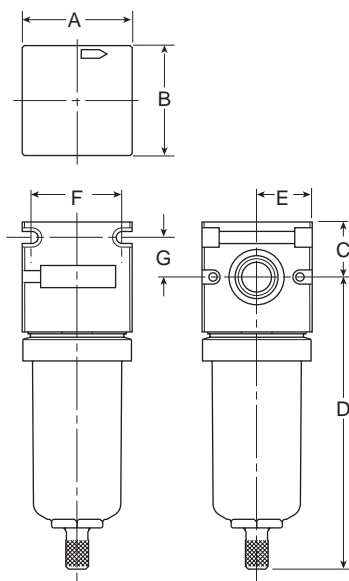

Dimensions

Models	Inches (mm)	A	B	C	D	E	F	G	H
Standard Unit X08-02-000		1.59 (40.5)	1.59 (40.5)	0.81 (20.6)	4.25 (107.9)	5.06 (128.5)	0.80 (20.2)	0.58 (14.7)	1.31 (33.3)

What is adsorption drying?

Drying compressed air through adsorption represents a purely physical process in which water vapor (adsorbate) is bound to the drying medium (adsorbent) through binding forces of molecular adhesion. Adsorbents are solids in spherical and granular form which are permeated by an array of pores. The water vapor is deposited onto the internal and external surface of the adsorption medium, without the formation of chemical compounds taking place, therefore the adsorption medium does not have to be replenished but only periodically regenerated.

Heatless

The layout of adsorption dryers with heatless regeneration is clear and simple. Compared with other adsorption dryer systems, pressure dewpoints down to -100°F (-73°C) can be achieved without additional effort.

Use in the higher pressure ranges and at low inlet temperatures causes the quantity of air needed for desorption to be reduced to an economical value.

At low operating pressure the demand for already dried compressed air for purposes of regeneration is increased. This increase causes a large proportion of the prepared compressed air to be no longer available for productive purposes.

Depending on the cycle, the quantity of air enclosed in the adsorber expands upon release at regular intervals with an emission noise level of about 90-95dB(A). Given suitable noise attenuation measures, a reduction of the noise emission level to the region of 10-15 dB(A) can be accomplished.

The use of adsorption dryers with heatless regeneration is preferred in the following applications:

- Capacity Range of Up to 800 SCFM
- Higher Pressure Ranges
- High Inlet Temperatures
- Installation in Explosion Proof Areas
- Use Under Ground Portable Applications
- Hazardous Locations (Pneumatic Controls)

Regenerative Desiccant Dryer

 = "Most Popular"

Features

- Point of use application bringing clean dry air just where you need it.
- Approved to International Standards designed in accordance with ASME VIII Div.1, approved to CSA/UL/CRN and fully CE Marked (PED, EMC, LVD) as standard.
- Simple to Install - flexible installation utilising the multiple in-line inlet & outlet connection ports.
- Compact and Lightweight - can be floor, bench or wall / canopy mounted.
- Very Quiet Operation - noise level less than 70dB(A).
- Can be Installed Almost Anywhere, IP66 / NEMA 4 protection as standard.
- Audible Alarm - indicating service interval for optimal performance.
- Simple & Easy to Maintain - due to the quick release top cap arrangement, which does NOT require the inlet / outlet ports to be disconnected as with traditional systems, maintenance can be achieved in under 15 minutes.

The WDAS is the reliable, cost effective and flexible way to provide clean dry air exactly where needed.



Operating Information

Operating Temperature	35°F (1.5°C) Max
Inlet Temperature	122°F (50°C) Max
Operating Pressure	58 to 175 PSIG (4 to 21 bar)
Flow Range	3 SCFM to 20 SCFM @ 100 PSIG (85 L/min to 567 L/min @ 7 bar)
Noise Level (Average)	70dB(A)
Pressure Dewpoint –	Standard -40°F (-40°C) pdp
Standard Electrical Supply	115/1ph/60Hz (Tolerance +/- 10%)
Controls	Electronic Control Timer
Connections	3/8 NPT

Dimensions & Ordering Information

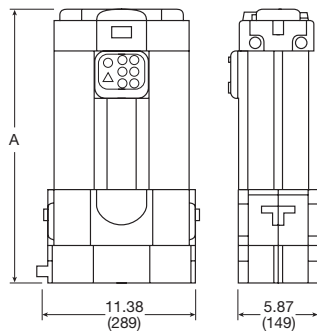

A	Weight (Kg)	SCFM	Part Number	Maintenance Kit
16.6 (422)	24.2 (11)	3	WDAS1	WDASMK1
19.7 (500)	28.7 (13)	5	WDAS2	WDASMK2
24.2 (616)	35.3 (16)	8	WDAS3	WDASMK3
27.2 (692)	39.7 (18)	10	WDAS4	WDASMK4
33.3 (847)	44.1 (20)	13	WDAS5	WDASMK5
35.7 (906)	50.7 (23)	15	WDAS6	WDASMK6
43.2 (1098)	61.7 (28)	20	WDAS7	WDASMK7



Service Kits

Description	Part Number
Mounting Bracket	
Fixed Wall	WDASMB1
45° Tilt Wall	WDASMB2

Sizing Chart (correction)

Minimum Inlet Pressure										
PSIG	58	73	87	100	116	135	145	160	175	
bar g	4	5	6	7	8	9	10	11	12	
Maximum Inlet Temperature										
95°F (35°C)	0.63	0.75	0.88	1.00	0.97	1.08	1.18	1.29	1.40	
104°F (40°C)	0.61	0.73	0.85	0.97	0.94	1.05	1.14	1.25	1.36	
113°F (45°C)	0.55	0.66	0.77	0.88	0.85	0.95	1.04	1.14	1.23	
122°F (50°C)	0.46	0.55	0.64	0.73	0.71	0.79	0.86	0.94	1.02	

Product applications

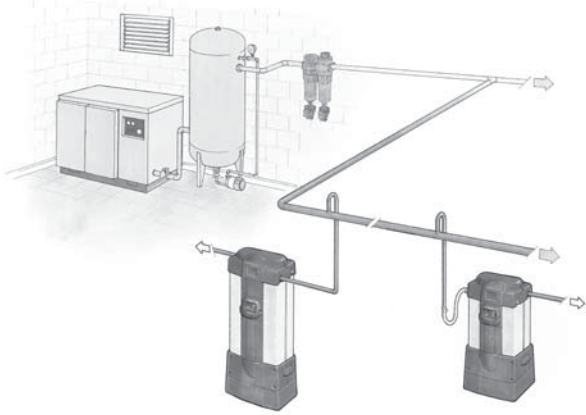

The Regenerative Desiccant Dryers will benefit users who have a specific need for Clean Dry Air (CDA) directly after a compressor, or for a particular application where the air is critical to the operating process or end product.

Typical applications:

- Computer Numerical Control (CNC) Machines
- Coordinate Measuring Machines
- Laboratories
- Lasers
- Packaging Machines
- Instrumentation
- Processing Equipment
- Conveying Machines

F

Dryers

ISO7000 inlet & outlet symbols cast into the top cover ensure correct piping installation.

One Combi-Cartridge per column containing DRYFIL® MS desiccant and a 1µm particulate filter.

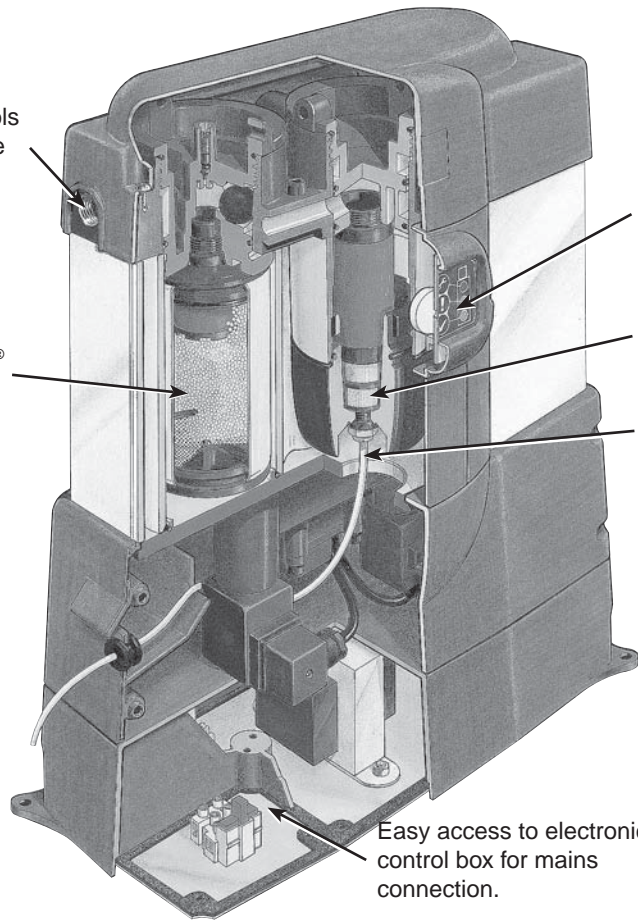

Electronic display providing high visibility LED indication with an internal audible alarm.

Integral 0.01µm high efficiency filter.

Positive removal of prefilter condensate by piping away for remote collection.

Easy access to electronic control box for mains connection.

- Compressed air enters the integral pre-filter and passes into the left hand chamber (Column A) where the air is dried before passing to the application.

A small amount of dry purge air is used to regenerate the right hand chamber (Column B) which is wet, using the PSA (Pressure Swing Adsorption) method of regeneration, venting the saturated air to atmosphere under pressure. The same regeneration air is also used to “back flush” the integral filter to prolong its working life.

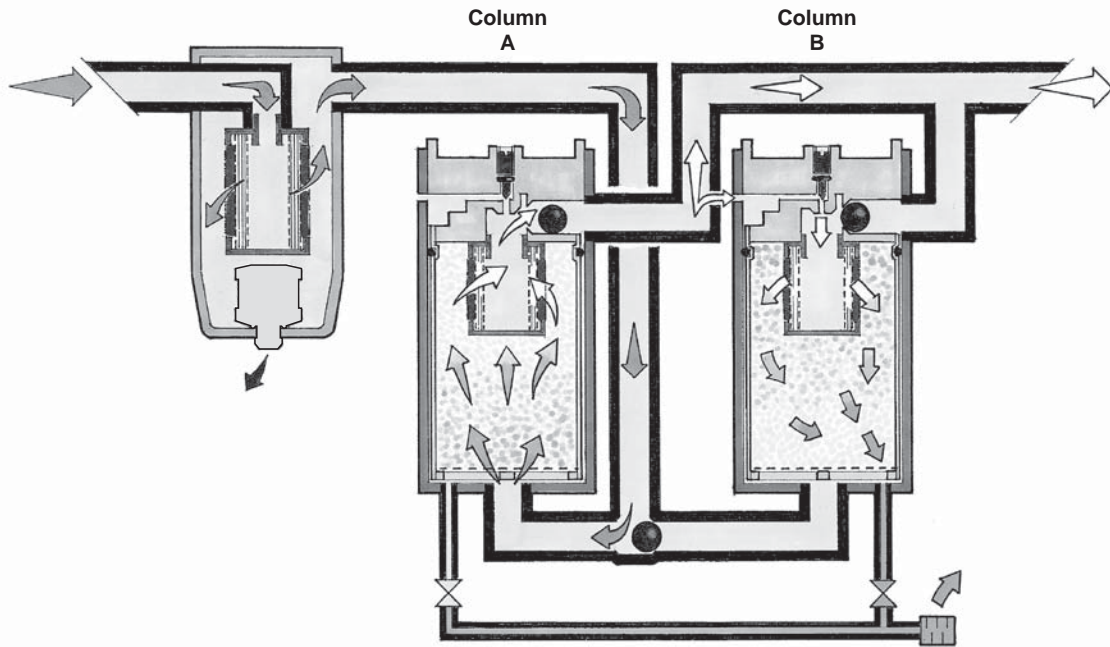

- Prior to changeover, the right hand chamber (Column B) enters repressurization where the exhaust valve is closed to allow pressure to increase. This process ensures a smooth uninterrupted changeover, preventing the loss of any system pressure, before the process repeats itself.

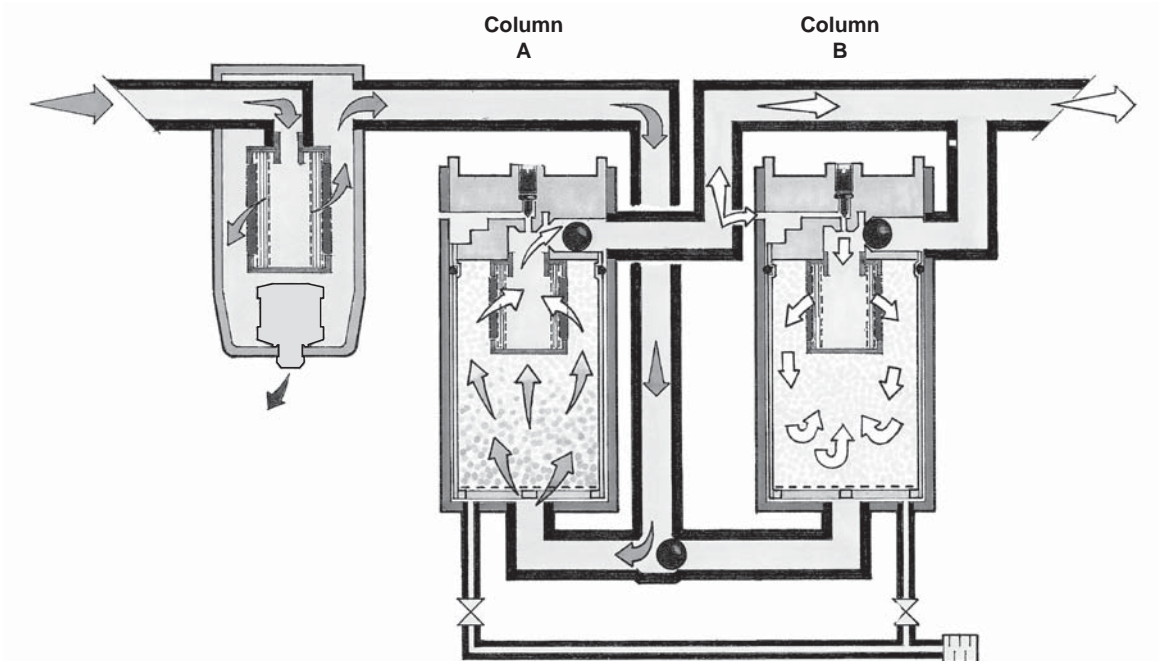

F
Dryers

Optional features

- For totally quiet operation, the regeneration exhaust air can be positively piped away.
- Remote indication provides a warning of the dryers need for servicing. (Audible alarm not included)
- Wall mounting kit for vertically securing the dryer to a wall or canopy.

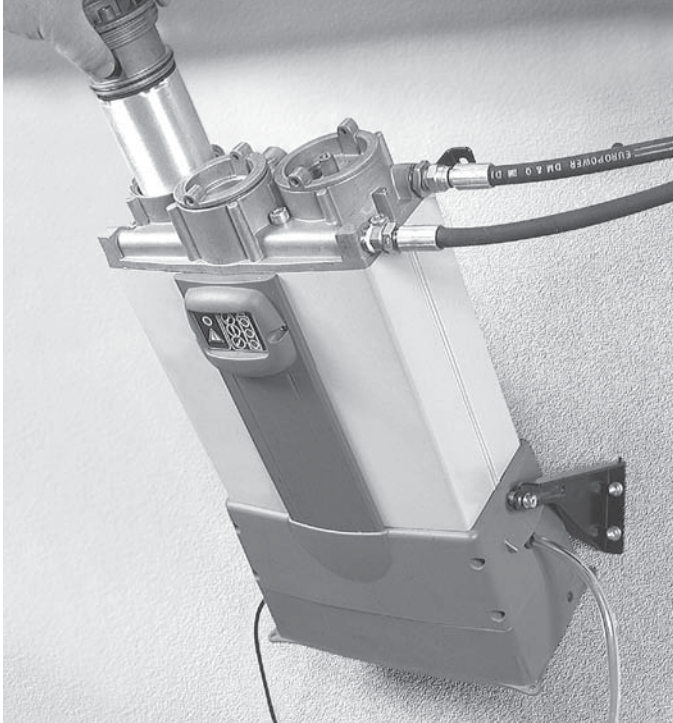

A 45° tilt, wall mounting kit is also available for vertically securing the dryer to a wall, canopy or inside a customers product where access to the top of the dryer is restricted.

- In conditions of limited access, the electronic control box (base) can be detached and relocated remotely from the dryer.



Electronic control box can be remotely located

Service indication sequence & alarm

During operation, The Regenerative Desiccant Dryers Power On (yellow) LED and Check (Green) LED indicators will illuminate, remaining in this configuration for 11500 hours. At this time, the Warning (Yellow) LED will illuminate and cancel the Check (Green) LED. This signals the user to order service replacement components at the optimum time.

500 hours later (a total of 12000 hours from initial start up) the Service (Red) LED will illuminate and cancel the Warning (Yellow) LED, the Audible Alarm housed inside the display will sound intermittently (every 6 seconds) drawing attention to the need for a service.



Heatless Desiccant Air Dryers WTW Series

= "Most Popular"

Parker WTW Series Heatless Desiccant Air Dryers remove water vapor from compressed air through a process known as pressure swing adsorption. Pressure dewpoints ranging from -40°F (-40°C) to -100°F (-70°C) are attained by directing the flow of saturated compressed air over a bed of desiccant.

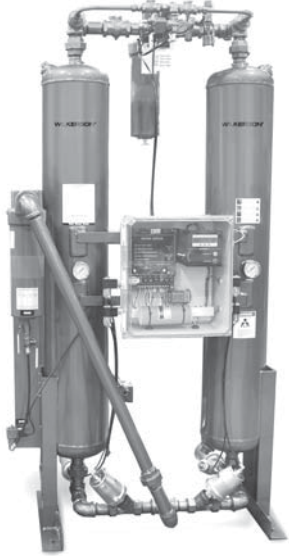

Features

- Pre-Filter and After Filters Included with Dryers
- Solid State Controller
- CycleLoc™ Demand Control
- Variable Cycle Control (Models WTW75 - WTW800 SCFM)
- Purge Flow Indicator
- Purge Flow Regulator (Models WTW75 - WTW800 SCFM)
- Repressurization Circuit (Models WTW75 - WTW800 SCFM)
- Control Air Filter (Models WTW75 - WTW800 SCFM)
- Safety Valves
- Pressure Equalization
- 150 PSIG Design Standard
- Moisture Indicator (Models WTW75 - WTW800 SCFM)

Operating Information

Inlet Or Ambient Air Temperature	120°F (49°C) maximum
Operating Pressure	50 PSIG (3.5 bar) minimum
Working Pressure	150 PSIG (10.5 bar) maximum
Pressure Drop At Rated Flow	Less than 5 PSI (0.34 bar)

Options

- DDS Light / DDS (Dewpoint Dependent Switching)

Heatless Desiccant Air Dryers

Capacity SCFM @ 100 PSIG (Nm³/min @ 6.9 bar)	Approximate Purge SCFM (Nm³/min)	Primary Voltage	Part Number	Port Size	Filtration Package Included With Dryer		
					Pre-filter (5µ)	Pre-filter (.01µ)	After-filter (0.5µ)
25 (.70)	4 (.11)	120V/1ph/60Hz	WTW25*	1/2	F18-04-SH00	M18-04-CG00	M18-04-BG00
42 (1.19)	6 (.19)	120V/1ph/60Hz	WTW40*	1/2	F28-04-SH00	M28-04-CG00	M28-04-BG00
60 (1.70)	9 (.25)	120V/1ph/60Hz	WTW55*	3/4	F28-06-SH00	M28-06-CH00	M28-06-BH00
75 (2.13)	11 (.31)	120V/1ph/60Hz	WTW75*	3/4	F39-06-SH00	M39-06-CH00	M39-06-BH00
107 (3.03)	16 (.45)	120V/1ph/60Hz	WTW100*	1	F39-08-SH00	M39-08-CH00	M39-08-BH00
135 (3.82)	20 (.56)	120V/1ph/60Hz	WTW130*	1	F39-08-SH00	M39-08-CH00	M39-08-BH00
200 (5.66)	30 (.84)	120V/1ph/60Hz	WTW200*	1-1/2	F35-0B-F00	M35-0B-F00	M35-0B-FS0
250 (7.07)	38 (1.07)	120V/1ph/60Hz	WTW250*	1-1/2	F35-0B-F00	M35-0B-F00	M35-0B-FS0
300 (8.49)	45 (1.27)	120V/1ph/60Hz	WTW300*	1-1/2	F35-0B-F00	M35-0B-F00	M35-0B-FS0
400 (11.32)	60 (1.69)	120V/1ph/60Hz	WTW400*	2	F35-0C-F00	M35-0C-F00	M35-0C-FS0
500 (14.44)	77 (2.18)	120V/1ph/60Hz	WTW500*	2	F35-0C-F00	M35-0C-F00	M35-0C-FS0
600 (18.40)	98 (2.77)	120V/1ph/60Hz	WTW600*	2	F35-0C-F00	M35-0C-F00	M35-0C-FS0
800 (22.65)	120 (3.39)	120V/1ph/60Hz	WTW800*	2	F35-0C-F00	M35-0C-F00	M35-0C-FS0

* Options: Dewpoint dependent switching (DDS).

DDS Light includes: energy saving purge cycle control with high humidity alarm and indicator light. When ordering use -DL as suffix.

DDS includes: energy saving purge cycle control with high humidity alarm and digital dewpoint display. When ordering use -DS as suffix.

Parker WTW Series Heatless Desiccant Air Dryers remove water vapor from compressed air through a process known as Pressure Swing Adsorption. Pressure dewpoints ranging from -40°F (-40°C) to -100°F (-70°C) are attained by directing the flow of saturated compressed air over a bed of desiccant.

This physically tough and chemically inert material is contained in two separate but identical pressure vessels commonly referred to as “dual” or “twin” towers.

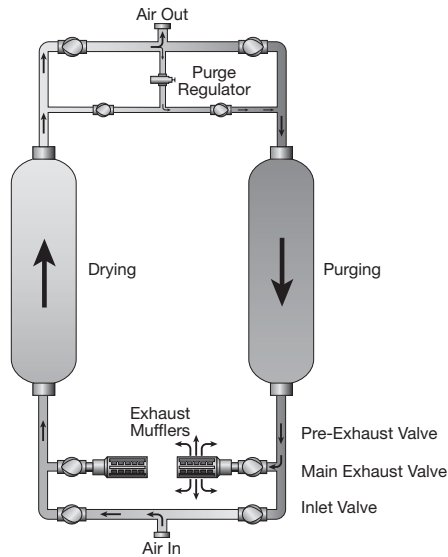

As the saturated compressed air flows up through the “on line” tower, its moisture content adheres to the surface of the desiccant. The dry compressed air is then discharged from the chamber into the distribution system.

A solid state controller automatically cycles the flow of compressed air between the towers, while the “on line” tower is drying, the “off line” tower is regenerating. Regeneration, sometimes referred to as purging, is the process by which moisture accumulated during the “on line” cycle is stripped away during the “off line” cycle. As low pressure dry purge air flows gently through the regenerating bed, it attracts the moisture that had accumulated on the surface of the desiccant during the drying cycle and exhausts it to the atmosphere.

To protect the desiccant bed from excess liquid, all Wilkerson WTW Series Heatless Air Dryers are designed to work with the natural pull of gravity. By directing the saturated air into the bottom of the “on line” tower and flowing up through the bed, liquid condensate caused by system upset, is kept away from the desiccant and remains at the bottom of the tower where it can be easily exhausted during the regeneration cycle. Counter flow purging ensures optimum performance by keeping the driest desiccant at the discharge end of the dryer.

Moisture load, velocity, cycle time and contact time determine tower size and the amount of desiccant. To ensure design dewpoint, each tower is carefully sized to allow a minimum of 5.5 seconds of contact. To prevent desiccant dusting and bed fluidization, air flow velocities are kept below 50 feet per minute. The dryer can cycle for years without changing the desiccant.

Heatless dryers in general are the most reliable and least expensive of all desiccant type dryers. Wilkerson WTW Series Heatless Desiccant Air Dryers are the most energy efficient thanks to standard features like, “Variable Cycle control”, Dewpoint Dependent Switching (DDS) and purge flow regulator.

Standard equipment

- Electric 120V/1PH/60Hz
- Solid State Controller
- Centrifugal Compressor Surge Protection (Models WTW75 - WTW800 SCFM)
- System Sequence Annunciator
- CycleLoc™ Demand Control
- Variable Cycle Control (Models WTW75 - WTW800 SCFM)
- Purge Flow Indicator
- Purge Flow Regulator (Models WTW75 - WTW800 SCFM)
- Repressurization Circuit (Models WTW75 - WTW800 SCFM)
- ASME Coded Pressure Vessels (Models WTW100 - WTW800 SCFM)
- Separate Tower Pressure Gauges
- Separate Fill / Drain Ports
- NEMA 4 Controls
- Stainless Steel Diffuser Screen
- Pressure Equalization
- 150 PSIG Design Standard
- Structural Steel Base
- Moisture Indicator (WTW25 - WTW800 SCFM)
- Pre and Post Filtration

Optional equipment

- Dewpoint Dependent Switching (DDS)
- 4-20 mA Output
- All NEMA Classifications
- Pressure to 1,000 PSIG (69 bar)
- High Humidity Alarm
- Fail to Switch Alarm
- Electronic Drain Systems
- -80°F (-62°C) to -100°F (-70°C) Dewpoints
- Contacts for Remote Alarms

Variable Cycle Control

Additional energy savings can be achieved by adjusting the amount of purge to the actual moisture load. When demand is expected to be less than maximum, Wilkerson's Variable Cycle Control provides a means to adjust the purge cycle time to reduce the total amount of purge used for regeneration. As a result of less frequent cycling, the desiccant will last longer and the switching valves will require less maintenance. The Variable Cycle Control incorporates a short cycle position that can be employed to provide dewpoints as low as -80°F (-60°C).

Surge Protection

To accommodate the unique requirements of centrifugal compressors, all Wilkerson desiccant dryers are now programmed with a special anti-surge control. A sequenced timing circuit eliminates potential compressor surge by preventing momentary flow restrictions from occurring at tower switch over.

Total dryer operation is managed by a NEMA 4 automatic control center. The solid state module controls all dryer functions including the Sequence Annunciator.

Sequence Annunciator

Wilkerson's Sequence Annunciator is a solid state visual display panel that shows exactly what is happening in the dryer. The panel lights signal which tower is "on line" drying, and whether the "off line" tower is purging, repressurizing or in Dewpoint Dependent Switching mode. It will also annunciate optional equipment operation and function alarms. The panel is integral with the NEMA 4 Master Control and is conveniently mounted for easy monitoring.

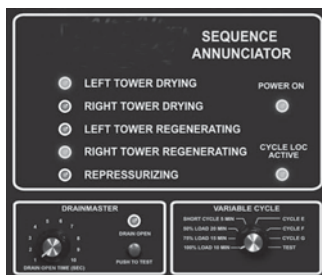

Dewpoint Dependent Switching (Optional)

Compressed air systems are rarely constant and the dryer regeneration cycle frequency is dependent upon the actual inlet flow, pressure and temperature. Operation under inlet conditions where there is lower than design flow and temperature and or higher pressure, will result in less regeneration cycles and a maximum in the cost of utilities.

Dewpoint Dependent Switching (DDS) provides a precision demand cycle control which terminates the adsorption (drying). This results in the full adsorptive capacity of the desiccant bed being utilized prior to switch over and regeneration.

DDS is built into the dryer control system, with a precision hygrometer producing a continuous display of the outlet dewpoint. The preset contacts of the instruments are utilized to initiate tower changeover.

Dewpoint Dependent Switching (DDS)

An Overview

The adsorption capacity of the desiccant within the dryer is essentially constant whereas the moisture loading and the air flow through the dryer are continuously varying as ambient and plant conditions change. In order to maintain the specified air quality downstream of the dryer, it has to be sized for the worst case conditions, namely the lowest pressure, highest flow and highest inlet temperature. These conditions may only occur for a small part of the service life of the dryer, for example, the highest inlet temperatures may only be present during the summer months. This means that the moisture loading on the desiccant beds is below the dryer's capacity for much of its service life (ie quiet periods in between shifts usually have lower air supply requirements). To gain access to this dynamic adsorption capacity, a moisture sensor is fitted which continually monitors the downstream dewpoint. DDS interrupts the normal sequence of the controller, which is only permitted to change over when the desiccant has adsorbed moisture to its capacity, effectively elongating the drying cycle. However, as regeneration has been optimized for a fully laden desiccant bed, this remains of constant duration resulting in a period of zero energy consumption (i.e. purging is discontinued). In this way, energy savings are obtained while maintaining a constant supply of clean dry air to your plant.



DDS

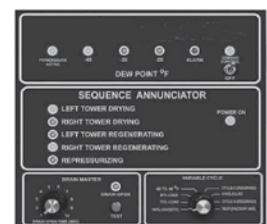

DDS Light

Flow correction factors

= "Most Popular"

Capacities are based upon:

- Pressure Drop At Rated Flow Less Than 5 PSI (0.34 bar)
- Maximum Inlet Air Or Ambient Air Temperature 120°F (49°C)
- Maximum Working Pressure: 150 PSIG (10.5 bar) Standard Units For High Maximum Working Pressure Are Available
- Minimum Operating Pressure: 50 PSIG (3.5 bar)

Inlet Air Pressure Correction

PSIG	50	60	70	80	90	100	110	120	130	140	150
bar	3.5	4.1	4.9	5.5	6.2	6.9	7.6	8.3	9.0	9.7	10.3
Factor	.56	.65	.74	.83	.91	1.00	1.09	1.18	1.27	1.37	1.43

Inlet Air Temperature Correction

°F	90	95	100	105	110	115	120
°C	32	35	38	41	43	46	49
Factor	1.35	1.16	1.00	.85	.74	.64	.56

Heatless Desiccant Air Dryers

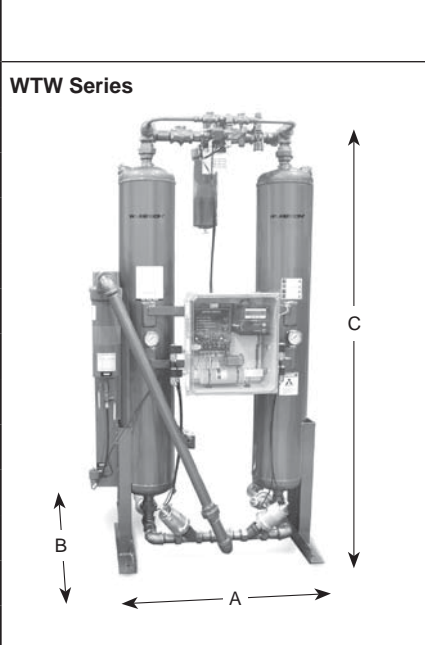
	Part Number	A (length)	B (width)	C (height)	Weight lbs. (kg)
	WTW25	19 (483)	16 (406)	64 (1626)	156 (71)
	WTW40	21 (533)	17 (432)	48 (1219)	190 (86)
	WTW55	21 (533)	20 (508)	67 (1702)	230 (104)
	WTW75	35 (889)	27 (686)	80 (2032)	384 (174)
	WTW100	35 (889)	27 (686)	80 (2032)	468 (212)
	WTW130	35 (899)	21 (533)	70 (1778)	496 (225)
	WTW200	44 (1118)	28 (711)	78 (1981)	692 (314)
	WTW250	44 (1118)	30 (762)	78 (1981)	776 (352)
	WTW300	44 (1118)	30 (762)	78 (1981)	796 (361)
	WTW400	74 (1880)	41 (1041)	84 (2134)	1626 (738)
	WTW500	74 (1880)	41 (1041)	85 (2159)	1735 (787)
	WTW600	74 (1880)	41 (1041)	86 (2184)	1740 (789)
WTW800	74 (1880)	41 (1041)	91 (2311)	2120 (962)	

Inch (mm)

Service Kits

Element Kits			
Series	5µ	0.01µ	0.5µ
18	FRP-96-639	MTP-96-646	MSP-96-647
28	FRP-96-653	MTP-96-648	MSP-96-649
39	P3NKA00ESE	P3NKA00ESCB	P3KNA00ES9
35	FRP-95-505	MTP-95-502	MSP-95-502

F

Dryers

Safety Guide For Selecting And Using Pneumatic Division Products And Related Accessories

WARNING:

FAILURE OR IMPROPER SELECTION OR IMPROPER USE OF PNEUMATIC DIVISION PRODUCTS, ASSEMBLIES OR RELATED ITEMS (“PRODUCTS”) CAN CAUSE DEATH, PERSONAL INJURY, AND PROPERTY DAMAGE. POSSIBLE CONSEQUENCES OF FAILURE OR IMPROPER SELECTION OR IMPROPER USE OF THESE PRODUCTS INCLUDE BUT ARE NOT LIMITED TO:

- Unintended or mistimed cycling or motion of machine members or failure to cycle
- Work pieces or component parts being thrown off at high speeds.
- Failure of a device to function properly for example, failure to clamp or unclamp an associated item or device.
- Explosion
- Suddenly moving or falling objects.
- Release of toxic or otherwise injurious liquids or gasses.

Before selecting or using any of these Products, it is important that you read and follow the instructions below.

1. GENERAL INSTRUCTIONS

- 1.1. Scope:** This safety guide is designed to cover general guidelines on the installation, use, and maintenance of Pneumatic Division Valves, FRLs (Filters pressure Regulators and Lubricators), Vacuum products and related accessory components.
- 1.2. Fail-Safe:** Valves, FRLs, Vacuum products and their related components can and do fail without warning for many reasons. Design all systems and equipment in a fail-safe mode, so that failure of associated valves, FRLs or Vacuum products will not endanger persons or property.
- 1.3 Relevant International Standards:** For a good guide to the application of a broad spectrum of pneumatic fluid power devices see: ISO 4414:1998, Pneumatic Fluid Power – General Rules Relating to Systems. See www.iso.org for ordering information.
- 1.4. Distribution:** Provide a copy of this safety guide to each person that is responsible for selection, installation, or use of Valves, FRLs or Vacuum products. Do not select, or use Wilkerson valves, FRLs or vacuum products without thoroughly reading and understanding this safety guide as well as the specific Wilkerson publications for the products considered or selected.
- 1.5. User Responsibility:** Due to the wide variety of operating conditions and applications for valves, FRLs, and vacuum products Wilkerson and its distributors do not represent or warrant that any particular valve, FRL or vacuum product is suitable for any specific end use system. This safety guide does not analyze all technical parameters that must be considered in selecting a product. The user, through its own analysis and testing, is solely responsible for:
 - Making the final selection of the appropriate valve, FRL, Vacuum component, or accessory.
 - Assuring that all user's performance, endurance, maintenance, safety, and warning requirements are met and that the application presents no health or safety hazards.
 - Complying with all existing warning labels and / or providing all appropriate health and safety warnings on the equipment on which the valves, FRLs or Vacuum products are used; and,
 - Assuring compliance with all applicable government and industry standards.
- 1.6. Safety Devices:** Safety devices should not be removed, or defeated.
- 1.7. Warning Labels:** Warning labels should not be removed, painted over or otherwise obscured.
- 1.8. Additional Questions:** Call the appropriate Wilkerson technical service department if you have any questions or require any additional information. See the Wilkerson publication for the product being considered or used, or call 269-629-2550, or go to www.wilkersoncorp.com, for telephone numbers of the appropriate technical service department.

2. PRODUCT SELECTION INSTRUCTIONS

- 2.1. Flow Rate:** The flow rate requirements of a system are frequently the primary consideration when designing any pneumatic system. System components need to be able to provide adequate flow and pressure for the desired application.
- 2.2. Pressure Rating:** Never exceed the rated pressure of a product. Consult product labeling, Pneumatic Division catalogs or the instruction sheets supplied for maximum pressure ratings.
- 2.3. Temperature Rating:** Never exceed the temperature rating of a product. Excessive heat can shorten the life expectancy of a product and result in complete product failure.
- 2.4. Environment:** Many environmental conditions can affect the integrity and suitability of a product for a given application. Pneumatic Division products are designed for use in general purpose industrial applications. If these products are to be used in unusual circumstances such as direct sunlight and/or corrosive or caustic environments, such use can shorten the useful life and lead to premature failure of a product.
- 2.5. Lubrication and Compressor Carryover:** Some modern synthetic oils can and will attack nitrile seals. If there is any possibility of synthetic oils or greases migrating into the pneumatic components check for compatibility with the seal materials used. Consult the factory or product literature for materials of construction.
- 2.6. Polycarbonate Bowls and Sight Glasses:** To avoid potential polycarbonate bowl failures:
 - Do not locate polycarbonate bowls or sight glasses in areas where they could be subject to direct sunlight, impact blow, or temperatures outside of the rated range.
 - Do not expose or clean polycarbonate bowls with detergents, chlorinated hydro-carbons, ketones, esters or certain alcohols.
 - Do not use polycarbonate bowls or sight glasses in air systems where compressors are lubricated with fire resistant fluids such as phosphate ester and di-ester lubricants.

2.7. Chemical Compatibility: For more information on plastic component chemical compatibility see Pneumatic Division technical bulletins Tec-3, Tec-4, and Tec-5

- 2.8. Product Rupture:** Product rupture can cause death, serious personal injury, and property damage.
- Do not connect pressure regulators or other Pneumatic Division products to bottled gas cylinders.
 - Do not exceed the maximum primary pressure rating of any pressure regulator or any system component.
 - Consult product labeling or product literature for pressure rating limitations.

3. PRODUCT ASSEMBLY AND INSTALLATION INSTRUCTIONS

3.1. Component Inspection: Prior to assembly or installation a careful examination of the valves, FRLs or vacuum products must be performed. All components must be checked for correct style, size, and catalog number. DO NOT use any component that displays any signs of nonconformance.

3.2. Installation Instructions: Wilkerson published Installation Instructions must be followed for installation of Wilkerson valves, FRLs and vacuum components. These instructions are provided with every Wilkerson valve or FRL sold, or by calling 269-629-2550, or at www.wilkersoncorp.com.

3.3. Air Supply: The air supply or control medium supplied to Valves, FRLs and Vacuum components must be moisture-free if ambient temperature can drop below freezing

4. VALVE AND FRL MAINTENANCE AND REPLACEMENT INSTRUCTIONS

4.1. Maintenance: Even with proper selection and installation, valve, FRL and vacuum products service life may be significantly reduced without a continuing maintenance program. The severity of the application, risk potential from a component failure, and experience with any known failures in the application or in similar applications should determine the frequency of inspections and the servicing or replacement of Pneumatic Division products so that products are replaced before any failure occurs. A maintenance program must be established and followed by the user and, at minimum, must include instructions 4.2 through 4.10.

4.2. Installation and Service Instructions: Before attempting to service or replace any worn or damaged parts consult the appropriate Service Bulletin for the valve or FRL in question for the appropriate practices to service the unit in question. These Service and Installation Instructions are provided with every Wilkerson valve and FRL sold, or are available by calling 269-629-2550, or by accessing the Wilkerson web site at www.wilkersoncorp.com.

4.3. Lockout / Tagout Procedures: Be sure to follow all required lockout and tagout procedures when servicing equipment. For more information see: OSHA Standard – 29 CFR, Part 1910.147, Appendix A, The Control of Hazardous Energy – (Lockout / Tagout)

4.4. Visual Inspection: Any of the following conditions requires immediate system shut down and replacement of worn or damaged components:

- Air leakage: Look and listen to see if there are any signs of visual damage to any of the components in the system. Leakage is an indication of worn or damaged components.
- Damaged or degraded components: Look to see if there are any visible signs of wear or component degradation.
- Kinked, crushed, or damaged hoses. Kinked hoses can result in restricted air flow and lead to unpredictable system behavior.
- Any observed improper system or component function: Immediately shut down the system and correct malfunction.
- Excessive dirt build-up: Dirt and clutter can mask potentially hazardous situations.

Caution: Leak detection solutions should be rinsed off after use.

4.5. Routine Maintenance Issues:

- Remove excessive dirt, grime and clutter from work areas.
- Make sure all required guards and shields are in place.

4.6. Functional Test: Before initiating automatic operation, operate the system manually to make sure all required functions operate properly and safely.

4.7. Service or Replacement Intervals: It is the user's responsibility to establish appropriate service intervals. Valves, FRLs and vacuum products contain components that age, harden, wear, and otherwise deteriorate over time. Environmental conditions can significantly accelerate this process. Valves, FRLs and vacuum components need to be serviced or replaced on routine intervals. Service intervals need to be established based on:

- Previous performance experiences.
- Government and / or industrial standards.
- When failures could result in unacceptable down time, equipment damage or personal injury risk.

4.8. Servicing or Replacing of any Worn or Damaged Parts: To avoid unpredictable system behavior that can cause death, personal injury and property damage:

- Follow all government, state and local safety and servicing practices prior to service including but not limited to all OSHA Lockout Tagout procedures (OSHA Standard – 29 CFR, Part 1910.147, Appendix A, The Control of Hazardous Energy – Lockout / Tagout).
- Disconnect electrical supply (when necessary) before installation, servicing, or conversion.
- Disconnect air supply and depressurize all air lines connected to system and Pneumatic Division products before installation, service, or conversion.
- Installation, servicing, and / or conversion of these products must be performed by knowledgeable personnel who understand how pneumatic products are to be applied.
- After installation, servicing, or conversions air and electrical supplies (when necessary) should be connected and the product tested for proper function and leakage. If audible leakage is present, or if the product does not operate properly, do not put product or system into use.
- Warnings and specifications on the product should not be covered or painted over. If masking is not possible, contact your local representative for replacement labels.

4.9. Putting Serviced System Back into Operation: Follow the guidelines above and all relevant Installation and Maintenance Instructions supplied with the valve FRL or vacuum component to insure proper function of the system.

Warning: Use Limitations

Wilkerson's warranties are void, and Wilkerson assumes no responsibility for any resulting cost, loss, injury or any other damages whatsoever, with respect to any plastic bowl unit for which a bowl guard is standard equipment if the unit is placed in service without the bowl guard and, except as otherwise specified in writing by Wilkerson, with respect to any Wilkerson products which are used in other than compressed air service. Specific warnings with respect to these and other use limitations appear elsewhere in this catalog.

Wilkerson maintains a policy of ongoing product development and improvement. We therefore reserve the right to change dimensions specification and design without notice.

Do not place plastic bowl unit in service without bowl guard installed.

Plastic bowl units are sold only with bowl guards with the exception to miniature units (C04, F00, L00, & M00). To minimize the danger of flying fragments in the event of plastic bowl failure, the bowl guards should not be removed. If the unit is in service without the bowl guard installed, manufacturer's warranties are void, and the manufacturer assumes no responsibility for any resulting loss.

If the unit has been in service and does not have a bowl guard, order one and install before placing back in service.

Caution

Certain compressor oils, chemicals, household cleaners, solvents, paints and fumes will attack plastic bowls and can cause bowl failure. Do not use near these materials. When bowl becomes dirty replace bowl or wipe only with a clean, dry cloth. Reinstall bowl guard or buy and install a bowl guard. Immediately replace any crazed, cracked, damaged or deteriorated plastic bowl with a bowl or a new plastic bowl and bowl guard.

Caution

Except as otherwise specified by the manufacturer, this product is specifically designed for compressed air service, and use with any other fluid (liquid or gas) is a misapplication. For example, use with or injection of certain hazardous liquids or gases in the system (such as alcohol or liquid petroleum gas) could be harmful to the unit or result in a combustible condition or hazardous external leakage. Before using with fluids other than air, or for non-industrial applications, or for life support systems, consult Wilkerson Operations for written approval.

Some of the Materials that will Attack Polycarbonate Plastic Bowls

Acetaldehyde	Chloroform	Milk of Lime (CaOH)
Acetic acid (conc.)	Cresol	Nitric Acid (conc.)
Acetone	Cyclohexanol	Nitrobenzene
Acrylonitrile	Cyclohexanone	Nitrocellulose Lacquer
Ammonia	Cyclohexene	Phenol
Ammonium Fluoride	Dimethyl Formamide	Phosphorous Hydroxy Chloride
Ammonium Hydroxide	Diozane	Perchloroethylene
Ammonium Sulfide	Ethgane tetrachloride	Phosphorous
Anaerobic adhesives	Ethyl Acetate	Propionic Acid
Trichloride and Sealants	Ethyl Ether	Pyridine
Antifreeze	Ethylamine	Sodium Hydroxide
Benzene	Ethylene Chlorohydrin	Sodium Sulfide
Benzoic Acid	Ethylene Dichloride	Styrene
Benzyl Alcohol	Ethylene Glycol	Sulfuric Acid (conc.)
Brake Fluids	Formic Acid (conc.)	Sulphural Chloride
Bromobenzene	Freon (Refrig. & Propell.)	Tetrahydronaphthalene
Butyric Acid	Gasoline (High Aromatic)	Tiophene
Carbolic Acid	Hydrazine	Toluene
Carbon Disulfide	Hydrochloric Acid (conc.)	Turpentine
Carbon Tetrachloride	Lacquer Thinner	Xylene & Others
Caustic Potash Solution	Methyl Alcohol	
Caustic Soda Solution	Methylene Chloride	
Chlorobenzene	Methylene Salicylate	

Trade Names of some Compressor Oils, Rubber Compounds and other Materials that will Attack Polycarbonate Plastic Bowls.

Atlas "Perma-Guard"	National Compound #N11
Buna N	"Nylock" VC-3
Cellulube #150 and #220	Parco #1306 Neoprene
Crylex #5 cement	*Permabond 910
*Eastman 910	Petron PD287
Garlock #98403 (polyurethane)	Prestone
Haskel #568-023	Pydraul AC
Hilgard Co.'s hil phene	Sears Regular Motor Oil
Houghton & Co. oil #1120, #1130 & #1055	Sinclair oil "Lily White"
Houtosafe 1000	Stauffer Chemical FYRQUEL #150
Kano Kroil	Stillman #SR 269-75 (polyurethane)
Keystone penetrating oil #2	Stillman #SR 513-70 (neoprene)
*Loctite 271	Tannergas
*Locite 290	Telar
*Loctite 601	Tenneco anderol #495 & #500 oils
*Loctite Teflon-Sealant	Titon
Marvel Mystery Oil	*Vibra-tite
Minn. Rubber 366Y	Zerex
*When in raw liquid form.	

We cannot possibly list all harmful substances, so check with Mobay or the General Electric office for further information on polycarbonate plastic.

The trade names "EconOmist" and "Flow-Guide" are registered at the United States Patent Office.

"Auto-Fill", "Dial-Air", "Flex-Drain", "Mainliner" and "Whirl-Flo" are tradenames of Wilkerson.

Claims and Shortages: Risk of loss passes to buyer when goods are delivered to the carrier. Inspect all shipments for damage at time of receipt. Claims should be filed by the consignee against the carrier.

Changes: Wilkerson maintains a policy of ongoing product development and improvement. We therefore reserve the right to change dimensions, specifications and design without notice.

Offer of Sale

The items described in this document and other documents and descriptions provided by The Company, its subsidiaries and its authorized distributors ("Seller") are hereby offered for sale at prices to be established by Seller. This offer and its acceptance by any customer ("Buyer") shall be governed by all of the following Terms and Conditions. Buyer's order for any item described in its document, when communicated to Seller verbally, or in writing, shall constitute acceptance of this offer. All goods or work described will be referred to as "Products".

1. Terms and Conditions. Seller's willingness to offer Products, or accept an order for Products, to or from Buyer is expressly conditioned on Buyer's assent to these Terms and Conditions and to the terms and conditions found on-line at www.parker.com/saleterms/. Seller objects to any contrary or additional term or condition of Buyer's order or any other document issued by Buyer.

2. Price Adjustments; Payments. Prices stated on the reverse side or preceding pages of this document are valid for 30 days. After 30 days, Seller may change prices to reflect any increase in its costs resulting from state, federal or local legislation, price increases from its suppliers, or any change in the rate, charge, or classification of any carrier. The prices stated on the reverse or preceding pages of this document do not include any sales, use, or other taxes unless so stated specifically. Unless otherwise specified by Seller, all prices are F.O.B. Seller's facility, and payment is due 30 days from the date of invoice. After 30 days, Buyer shall pay interest on any unpaid invoices at the rate of 1.5% per month or the maximum allowable rate under applicable law.

3. Delivery Dates; Title and Risk; Shipment. All delivery dates are approximate and Seller shall not be responsible for any damages resulting from any delay. Regardless of the manner of shipment, title to any products and risk of loss or damage shall pass to Buyer upon tender to the carrier at Seller's facility (i.e., when it's on the truck, it's yours). Unless otherwise stated, Seller may exercise its judgment in choosing the carrier and means of delivery. No deferment of shipment at Buyer's request beyond the respective dates indicated will be made except on terms that will indemnify, defend and hold Seller harmless against all loss and additional expense. Buyer shall be responsible for any additional shipping charges incurred by Seller due to Buyer's changes in shipping, product specifications or in accordance with Section 13, herein.

4. Warranty. Seller warrants that the Products sold hereunder shall be free from defects in material or workmanship for a period of twelve months from the date of delivery to Buyer or 2,000 hours of normal use, whichever occurs first. This warranty is made only to Buyer and does not extend to anyone to whom Products are sold after purchased from Seller. The prices charged for Seller's products are based upon the exclusive limited warranty stated above, and upon the following disclaimer: **DISCLAIMER OF WARRANTY: THIS WARRANTY COMPRISES THE SOLE AND ENTIRE WARRANTY PERTAINING TO PRODUCTS PROVIDED HEREUNDER. SELLER DISCLAIMS ALL OTHER WARRANTIES, EXPRESS AND IMPLIED, INCLUDING MERCHANTABILITY AND FITNESS FOR A PARTICULAR PURPOSE.**

5. Claims; Commencement of Actions. Buyer shall promptly inspect all Products upon delivery. No claims for shortages will be allowed unless reported to the Seller within 10 days of delivery. No other claims against Seller will be allowed unless asserted in writing within 60 days after delivery or, in the case of an alleged breach of warranty, within 30 days after the date within the warranty period on which the defect is or should have been discovered by Buyer. Any action based upon breach of this agreement or upon any other claim arising out of this sale (other than an action by Seller for any amount due to Seller from Buyer) must be commenced within thirteen months from the date of tender of delivery by Seller or, for a cause of action based upon an alleged breach of warranty, within thirteen months from the date within the warranty period on which the defect is or should have been discovered by Buyer.

6. LIMITATION OF LIABILITY. UPON NOTIFICATION, SELLER WILL, AT ITS OPTION, REPAIR OR REPLACE A DEFECTIVE PRODUCT, OR REFUND THE PURCHASE PRICE. IN NO EVENT SHALL SELLER BE LIABLE TO BUYER FOR ANY SPECIAL, INDIRECT, INCIDENTAL OR CONSEQUENTIAL DAMAGES ARISING OUT OF, OR AS THE RESULT OF, THE SALE, DELIVERY, NON-DELIVERY, SERVICING, USE OR LOSS OF USE OF THE PRODUCTS OR ANY PART THEREOF, OR FOR ANY CHARGES OR EXPENSES OF ANY NATURE INCURRED WITHOUT SELLER'S WRITTEN CONSENT, EVEN IF SELLER HAS BEEN NEGLIGENT, WHETHER IN CONTRACT, TORT OR OTHER LEGAL THEORY. IN NO EVENT SHALL SELLER'S LIABILITY UNDER ANY CLAIM MADE BY BUYER EXCEED THE PURCHASE PRICE OF THE PRODUCTS.

7. Contingencies. Seller shall not be liable for any default or delay in performance if caused by circumstances beyond the reasonable control of Seller.

8. User Responsibility. The user, through its own analysis and testing, is solely responsible for making the final selection of the system and Product and assuring that all performance, endurance, maintenance, safety and warning requirements of the application are met. The user must analyze all aspects of the application and follow applicable industry standards and Product information. If Seller provides Product or system options, the user is responsible for determining that such data and specifications are suitable and sufficient for all applications and reasonably foreseeable uses of the Products or systems.

9. Loss to Buyer's Property. Any designs, tools, patterns, materials, drawings, confidential information or equipment furnished by Buyer or any other items which become Buyer's property, may be considered obsolete and may be destroyed by Seller after two consecutive years have elapsed without Buyer placing an order for the items which are manufactured using such property. Seller shall not be responsible for any loss or damage to such property while it is in Seller's possession or control.

10. Special Tooling. A tooling charge may be imposed for any special tooling, including without limitation, dies, fixtures, molds and patterns, acquired to manufacture Products. Such special tooling shall be and remain Seller's property notwithstanding payment of any charges by Buyer. In no event will Buyer acquire any interest in apparatus belonging to Seller which is utilized in the manufacture of the Products, even if such apparatus has been specially converted or adapted for such manufacture and notwithstanding any charges paid by Buyer. Unless otherwise agreed, Seller shall have the right to alter, discard or otherwise dispose of any special tooling or other property in its sole discretion at any time.

11. Buyer's Obligation; Rights of Seller. To secure payment of all sums due or otherwise, Seller shall retain a security interest in the goods delivered and this agreement shall be deemed a Security Agreement under the Uniform Commercial Code. Buyer authorizes Seller as its attorney to execute and file on Buyer's behalf all documents Seller deems necessary to perfect its security interest. Seller shall have a security interest in, and lien upon, any property of Buyer in Seller's possession as security for the payment of any amounts owed to Seller by Buyer.

12. Improper use and Indemnity. Buyer shall indemnify, defend, and hold Seller harmless from any claim, liability, damages, lawsuits, and costs (including attorney fees), whether for personal injury, property damage, patent, trademark or copyright infringement or any other claim, brought by or incurred by Buyer, Buyer's employees, or any other person, arising out of: (a) improper selection, improper application or other misuse of Products purchased by Buyer from Seller; (b) any act or omission, negligent or otherwise, of Buyer; (c) Seller's use of patterns, plans, drawings, or specifications furnished by Buyer to manufacture Product; or (d) Buyer's failure to comply with these terms and conditions. Seller shall not indemnify Buyer under any circumstance except as otherwise provided.

13. Cancellations and Changes. Orders shall not be subject to cancellation or change by Buyer for any reason, except with Seller's written consent and upon terms that will indemnify, defend and hold Seller harmless against all direct, incidental and consequential loss or damage. Seller may change product features, specifications, designs and availability with notice to Buyer.

14. Limitation on Assignment. Buyer may not assign its rights or obligations under this agreement without the prior written consent of Seller.

15. Entire Agreement. This agreement contains the entire agreement between the Buyer and Seller and constitutes the final, complete and exclusive expression of the terms of the agreement. All prior or contemporaneous written or oral agreements or negotiations with respect to the subject matter are herein merged.

16. Waiver and Severability. Failure to enforce any provision of this agreement will not waive that provision nor will any such failure prejudice Seller's right to enforce that provision in the future. Invalidation of any provision of this agreement by legislation or other rule of law shall not invalidate any other provision herein. The remaining provisions of this agreement will remain in full force and effect.

17. Termination. This agreement may be terminated by Seller for any reason and at any time by giving Buyer thirty (30) days written notice of termination. In addition, Seller may by written notice immediately terminate this agreement for the following: (a) Buyer commits a breach of any provision of this agreement (b) the appointment of a trustee, receiver or custodian for all or any part of Buyer's property (b) the filing of a petition for relief in bankruptcy of the other Party on its own behalf, or by a third party (c) an assignment for the benefit of creditors, or (d) the dissolution or liquidation of the Buyer.

18. Governing Law. This agreement and the sale and delivery of all Products hereunder shall be deemed to have taken place in and shall be governed and construed in accordance with the laws of the State of Ohio, as applicable to contracts executed and wholly performed therein and without regard to conflicts of laws principles. Buyer irrevocably agrees and consents to the exclusive jurisdiction and venue of the courts of Cuyahoga County, Ohio with respect to any dispute, controversy or claim arising out of or relating to this agreement. Disputes between the parties shall not be settled by arbitration unless, after a dispute has arisen, both parties expressly agree in writing to arbitrate the dispute.

19. Indemnity for Infringement of Intellectual Property Rights. Seller shall have no liability for infringement of any patents, trademarks, copyrights, trade dress, trade secrets or similar rights except as provided in this Section. Seller will defend and indemnify Buyer against allegations of infringement of U.S. patents, U.S. trademarks, copyrights, trade dress and trade secrets ("Intellectual Property Rights"). Seller will defend at its expense and will pay the cost of any settlement or damages awarded in an action brought against Buyer based on an allegation that a Product sold pursuant to this Agreement infringes the Intellectual Property Rights of a third party. Seller's obligation to defend and indemnify Buyer is contingent on Buyer notifying Seller within ten (10) days after Buyer becomes aware of such allegations of infringement, and Seller having sole control over the defense of any allegations or actions including all negotiations for settlement or compromise. If a Product is subject to a claim that it infringes the Intellectual Property Rights of a third party, Seller may, at its sole expense and option, procure for Buyer the right to continue using the Product, replace or modify the Product so as to make it noninfringing, or offer to accept return of the Product and return the purchase price less a reasonable allowance for depreciation. Notwithstanding the foregoing, Seller shall have no liability for claims of infringement based on information provided by Buyer, or directed to Products delivered hereunder for which the designs are specified in whole or part by Buyer, or infringements resulting from the modification, combination or use in a system of any Product sold hereunder. The foregoing provisions of this Section shall constitute Seller's sole and exclusive liability and Buyer's sole and exclusive remedy for infringement of Intellectual Property Rights.

20. Taxes. Unless otherwise indicated, all prices and charges are exclusive of excise, sales, use, property, occupational or like taxes which may be imposed by any taxing authority upon the manufacture, sale or delivery of Products.

21. Equal Opportunity Clause. For the performance of government contracts and where dollar value of the Products exceed \$10,000, the equal employment opportunity clauses in Executive Order 11246, VEVRAA, and 41 C.F.R. §§ 60-1.4(a), 60-741.5(a), and 60-250.4, are hereby incorporated.